

# Packaging Specifications Mercedes-Benz U.S. International, Inc.

**19 February 2018**

Please be advised that after reading this Specification, an Acknowledgment Sheet, located at the very end, will need to be signed and submitted after each revision of this document.

History of Changes – See Page iii

# Table of Contents

|   |            |
|---|------------|
| <b>HISTORY OF CHANGES</b> .....   | <b>iii</b> |
| <b>I. PACKAGING DATA FORM</b> .....   | <b>1</b>   |
| <b>II. RETURNABLE PACKAGING SPECIFICATIONS – Prior to BR167</b> .....             | <b>1</b>   |
| <b>III. RETURNABLE PACKAGING SPECIFICATIONS – BR167 and future projects</b> ..... | <b>5</b>   |
| <b>IV. eCon CONTAINER MANAGEMENT</b> .....  | <b>9</b>   |
| <b>V. EXPENDABLE PACKAGING</b> .....  | <b>10</b>  |
| <b>VI. ERGONOMICS AND SAFETY</b> .....  | <b>12</b>  |
| <b>VII. PART COMBINATIONS</b> .....   | <b>13</b>  |
| <b>VIII. LABELING</b> .....   | <b>14</b>  |
| <b>IX. PACKAGING IDENTIFICATION</b> .....   | <b>14</b>  |
| <b>X. RFID IDENTIFICATION – BR167 and future projects</b> .....                   | <b>16</b>  |
| <b>XI. STEEL RACK IDENTIFICATION</b> .....  | <b>16</b>  |
| <b>XII. ASSEMBLY SHOP RACK SPECIFICATIONS</b> .....                               | <b>18</b>  |
| <b>XIII. BODY SHOP SPECIFICATIONS</b> .....                                       | <b>18</b>  |
| <b>XIV. ROBOTIC RACK MAINTENANCE REQUIREMENTS</b> .....                           | <b>19</b>  |
| <b>XV. RETURNABLE PACKAGING OWNERSHIP AND MANAGEMENT</b> .....                    | <b>19</b>  |
| <b>XVI. TOTAL PREVENTIVE MAINTENANCE (TPM)</b> .....                              | <b>20</b>  |
| <b>XVII. DEBIT AND PENALTIES SUMMARY</b> .....                                    | <b>21</b>  |
| <b>XVIII. MBUSI-SUPPLIER COOPERATION</b> .....                                    | <b>21</b>  |
| <b>XIX. STORAGE REQUIREMENTS</b> .....  | <b>22</b>  |
| <b>XX. REFERENCE DOCUMENTS</b> .....  | <b>23</b>  |
| <b>Attachment “A” – Packaging identification, Prior to BR167</b> .....            | <b>24</b>  |
| <b>Attachment “B” – Packaging identification, BR167 and future projects</b> ..... | <b>35</b>  |
| <b>Attachment “C” – Assembly Shop Standard Rack Base</b> .....                    | <b>45</b>  |
| <b>Acknowledgement Sheet – Packaging Specifications</b> .....                     | <b>48</b>  |

# HISTORY OF CHANGES

| Revision | Date        | Changes  |
|----------|-------------|--|
| 0        | 7/24/12     | Initial Release  |
| 1        | 7/18/13     | <ul style="list-style-type: none"> <li>Deleted reference to Model 205 from Title Page and first page. These specifications will be effective for all active 205 plus any vehicle parts released as of the Specifications effectively date. (pp. 1 and 1)</li> <li>Updated footer to reference new path and filename. (pp. all)</li> <li>Added NAFTA Supplier responsibility statement. (p.1)</li> <li>Deleted reference to PMC acronym. ( pp. 1, 7, 13)</li> <li>Updated standard container codes to reflect the new identification format. (pp. 1-3, 7)</li> <li>Updated setup charge for artwork. (p. 2)</li> <li>Deleted requirement for cardholders. (pp. 2, 3, 7)</li> <li>Added notification of 2<sup>nd</sup> label/tag to identify containers with dunnage. (pp. 3, 4)</li> <li>Added reference to new Attachment A. (pp. 3, 4, 7)</li> <li>Added Attachment A. (pp. 15-19)</li> <li>Changed Reference letter on Attachments previously called out as A, B, and C. (pp. 5, 9, 11-13, 20-23)</li> <li>Changed reference from “dunnage” to “insert/dunnage”. (pp 3, 5-7, 11, 20)</li> <li>Added statement to secure bottom layer of inserts/dunnage to container. (p. 4)</li> <li>Added statement of removable insert/dunnage durability and weight limits. (p. 6)</li> <li>Added recommendation for Supplier to obtain 1<sup>st</sup> Article audit sheets for racks that have parts robotically picked. (p. 9)</li> <li>Added timing when monthly TPM report are due. (p. 12)</li> <li>Added reminder that returnable containers used for Service Parts or SKD are to be purchased in addition to production requirements. (p. 12)</li> <li>Updated Attachment B with callout for Approved Packaging / pack quantity and requirement for expendable dimensions and picture if not match returnable criteria. (p.20)</li> </ul> |
| 2        | 9/12/13     | <ul style="list-style-type: none"> <li>Corrected Buckhorn container reference on all T57 totes. (pp. 1, 2)</li> <li>Corrected dimensions of T564228. (p. 2)</li> <li>Added reference to number of doors on bulk bins. (p. 2)</li> <li>Corrected Buckhorn container reference T560125 and T560134. (p. 2)</li> <li>Changed standard color from green to black for T560125 and T566425. (p. 2)</li> <li>Updated title of Pallet / Top Cap section. (p. 2)</li> <li>Added T550706, T550704, T550712 for ESD tote lid designations. (p. 2)</li> <li>Changed letter color on new artwork setup charges to emphasize new costs to Suppliers. (pp. 2, 4)</li> <li>Added reference to Attachment B, C, and D. Label Artwork Forms. (pp. 4, 7)</li> <li>Added statement regarding storage of containers. (p. 14)</li> <li>Updated Attachment A title for each bulk bin tag type. (p. 15)</li> <li>Corrected reference to new container code T564228. (p. 19)</li> <li>Added picture reference to location of label / tags on containers and tote lid. (pp. 17 – 19, 21 – 24)</li> <li>Added Attachment B, C and D. (pp. 25 – 27)</li> <li>Changed Reference letter on Attachments previously called out as B, C and D. (pp. 5, 9, 12-13, 23-26)</li> </ul>  |
| 3        | 9 Oct 2013  | <ul style="list-style-type: none"> <li>Updated footer to reference correct storage path. (all pages)</li> <li>Corrected number of Supplier ID labels on T5224 small totes. (p. 3)</li> <li>Corrected title of MBUSI group responsible for approval of packaging. (p. 3)</li> <li>Corrected Supplier Communication Guide Label Specification path.( pp. 6, 7)</li> <li>Corrected locations of TPM and Rack Serialization labels on racks. (p. 9)</li> <li>Added field for number of containers/lids ordered per label type. (p. 25 – 27)</li> <li>Updated Attachment G picture of REDTAG to current revision. (p. 31)</li> </ul>  |
| 4        | 14 May 2014 | <ul style="list-style-type: none"> <li>Updated decorations included in price per container size. (p. 3)</li> <li>Added statement describing what costs are associated with Attachment “E”. (p. 5)</li> </ul>   |

|                |             |  |
|----------------|-------------|--|
| 4<br>Continued | 14 May 2014 | <ul style="list-style-type: none"> <li>• Added statement for use of card holders. (p. 7)</li> <li>• Added debit amount per tote for missing or broken cardholders (p. 13)</li> <li>• Updated statement of what not to place anything over. (p. 13)</li> <li>• Updated tote drawings with cardholders. (pp 21 – 24)</li> <li>• Separated out T52 and T57_0607 from T52 and T57_0609_0614 tote drawings. (p. 22)</li> <li>• Clarified unclear statement regarding what approved returnable packaging is. (p. 29)</li> <li>• Updated picture of Repair Tag, Attachment G. (p. 32)</li> </ul>  |
| 5              | 31 Mar 2016 | <ul style="list-style-type: none"> <li>• Added definition for SHALL versus SHOULD. (p. 1)</li> <li>• Capitalized and bolded all references to SHALL and SHOULD. (all)</li> <li>• Updated reference artwork form titles. (pp. 2-3)</li> <li>• Changed SHOULD to SHALL regarding bottom dunnage layer secured in container. (p.4)</li> <li>• Updated RAN to RAN/HU to cover transition to AM Supply. (pp. 4, 7, 9, 10, 30)</li> <li>• Added compliance requirement date. (p. 5)</li> <li>• Updated reference document number for Alternate Packaging Form. (pp. 5, 6, 14, 15)</li> <li>• Changed color of wording for advance notice of expendable shipments. (p. 5)</li> <li>• Added picture of telescopic lid. (p. 5)</li> <li>• Added requirement for expendable stack height markings. (p. 6)</li> <li>• Updated requirement for expendable PDF to be submitted. (p. 6)</li> <li>• Added statement regarding wood in expendables. (p. 6)</li> <li>• Added recommended wall thickness for expendables. (p. 6)</li> <li>• Added statement regarding use of wooden pallets. (p. 6)</li> <li>• Clarified wording for when MIXED LOAD versus MASTER label should be used. (p. 7)</li> <li>• Added timeline for implementation of new label size. (p. 8)</li> <li>• Clarified what information found on the RAN/HU label is passed through the EDI system to the Supplier. (p. 8)</li> <li>• Updated wording for cardholders on new orders. (p. 8)</li> <li>• Updated reference document number for artwork forms. (p. 8)</li> <li>• Changed SHOULD to SHALL regarding ID placards on racks. (p. 10)</li> <li>• Changed SHOULD to SHALL regarding rack ID stenciling and kickplate height. (p. 11)</li> <li>• Changed CATIA to Siemens NX., (p. 11)</li> <li>• Corrected dimension of Body Shop standard footprint dimensions. (p. 12)</li> <li>• Update reference document for Repair Request Tag. (p. 13)</li> <li>• Changed SHOULD to SHALL regarding next TPM schedule on rack. (p. 14)</li> <li>• Added statement regarding repack charges. (p. 14)</li> <li>• Change in charge back rates for unapproved shipments in expendables. (p. 14)</li> <li>• Corrected dimensions of Supplier ID label for T564228 bulk bin. (pp. 17, SCGPA03)</li> <li>• Corrected dimensions of Special Dunnage ID label for T564228 bulk bin. (pp. 21, SCGPA04)</li> <li>• Added lines to enter total number of top caps and pallets ordered. (pp. SCGPA05, SCGPA04)</li> <li>• Updated wording for Supplier to enter approved packaging code and associated pack quantity. (p. SCGPA11)</li> <li>• Added question if unit load is stackable. (p. SCGPA11)</li> <li>• Moved Attachments B, C, D, E, and G to separate documents and add reference section to Specification outline. (pp. 16, SCGPA05, SCGPA03, SCGPA04, SCGPA11, Red Tag)</li> <li>• Changed Attachment F to be called now called Attachment B. (pp. 11, 28-29)</li> </ul> |
| 6              | 15 Sep 2016 | <ul style="list-style-type: none"> <li>• Changed title of Section II to separate prior to BR167 returnable packaging specifications from BR167 forward returnable packaging specifications. (p. 1)</li> <li>• Added column titles to Standard container listing. (p. 2, 3)</li> <li>• Added reference to new document. (p. 3, 4, 7, 8, 14)</li> <li>• Corrected explanation of height of racks. (p. 4)</li> <li>• Changed nomenclature for Logistics Center from PCC to MLC. (p. 4)</li> <li>• Added SHALL to enforce requirement for properly securing pallet loads. (p. 5, 9)</li> <li>• Added Section III for BR167 forward returnable packaging specifications. (p. 5-9)</li> <li>• Due to adding BR167 section, all other sections changed their section numbers accordingly. (p. 9-21)</li> <li>• Clarified flute wall thickness for expendable packaging. (p. 10, 11)</li> <li>• Changed terminology of expendable wall thickness from layer to flute. (p. 10, 11)</li> </ul>   |

|                        |                     |  |
|------------------------|---------------------|--|
| <p>6<br/>Continued</p> | <p>15 Sep 2016</p>  | <ul style="list-style-type: none"> <li>• Added specification for expendable flute thickness. (p. 10, 11)</li> <li>• Added statement for method of securing containers to wooden pallets and use of expendable telescopic lids. (p. 11)</li> <li>• Deleted requirement for only specialty racks to be free of sharp edges. All racks are required to be free of sharp edges and burrs. (p. 11)</li> <li>• Added statement that all expendable packaging shall comply with Section IV. (p. 12)</li> <li>• Added statement that all old labels must be removed prior to new labels applied. (p. 12)</li> <li>• Modified 4" x 6" label size statement to only accommodate Suppliers not switched over to CUM ordering. (p. 12)</li> <li>• Changed 'Buckhorn' to 'Approved Container Suppliers'. (p. 13)</li> <li>• Added reference to attachments for locations of all labels. (p. 13)</li> <li>• Separated statements on what label information was being passed via EDI to the Supplier. RAN versus Handling Unit. (p. 13)</li> <li>• Added reference page for BR167 number of cardholders on each tote. (p. 13)</li> <li>• Added reference to Attachment B for BR167 container identification. (p. 13)</li> <li>• Added visual example of hot stamp on ESD tote returnable lids. (p. 13)</li> <li>• Added BR167 hot stamp examples. (p. 14)</li> <li>• Clarified information required to be on all returnable inserts/dunnage. (p. 14)</li> <li>• Changed SHOULD to SHALL for rack serialization with metal plate. (p. 14)</li> <li>• Added requirement for use of Placard label holder on each rack placard. (p. 15)</li> <li>• Specified location of Identification Placards on rack (Point 5). (p. 15)</li> <li>• Changed 'must' to SHALL for TPM Sticker requirement. (p. 15)</li> <li>• Changed 'required' to SHALL for TPM Sticker design use on metal racks. (p. 15)</li> <li>• Updated potential source for TPM Sticker design. (p. 15)</li> <li>• Added reference to placard design on Assembly Shop standard rack base Attachment. (p. 16)</li> <li>• Changed Assembly Shop standard rack base Attachment reference. (p. 16)</li> <li>• Updated matrix for color coded BR167 forward Body Shop racks. (p. 16)</li> <li>• Updated LH versus RH color coding on racks. (p. 17)</li> <li>• Clarified what returnable packaging constitutes. (p. 18)</li> <li>• Added SHALL to requirement for proof of fleet packaging. (p. 18)</li> <li>• Added trays to list of TPM applicable packaging. (p. 19)</li> <li>• Corrected when monthly TPM report is due. (p.19)</li> <li>• Updated Debits and Penalties to summary form, modified amounts. (p.19)</li> <li>• Updated Department Title. (p. 20)</li> <li>• Added SHALL to statement of what not to place over crucial areas of containers. (p. 20)</li> <li>• Changed Attachment A title to refer to Prior to BR167 Container Identification. (pp. 22)</li> <li>• Inserted Attachment B for BR167 forward Container identification. (pp. 7, 8, 13, 33-39)</li> <li>• Changed previous Attachment B title to Attachment C due to insertion of new Attachment.. (pp. 16, 40, 41)</li> </ul> |
| <p>7</p>               | <p>31 July 2017</p> | <ul style="list-style-type: none"> <li>• Added Acknowledgement Sheet notification, (p. 1)</li> <li>• Changed wording from container to packaging to be consistent across all documents. (pp. All)</li> <li>• Clarified internal delivery philosophy statement. (pp. 4, 8)</li> <li>• Added reference to Buckhorn spec pricing horizontal. (pp. 4, 22)</li> <li>• Added ESD compliance formula and standard compliance document number. (pp. 4, 8)</li> <li>• Deleted reference to RAN. (pp. 5, 13, 14, 16, 20)</li> <li>• Updated packaging dimensions for Rank 1 packaging suppliers. (pp. 6-7)</li> <li>• Updated Artwork statement and reference to new documents. (p. 7)</li> <li>• Clarified decorations on all totes, bulk bins, pallets, and top caps. (p. 7)</li> <li>• Added new documents references. (pp. 7, 8, 11, 12, 14, 15, 19, 22, 23)</li> <li>• Deleted cardholder requirement for totes (BR167 forward). (pp. 7, 14)</li> <li>• Added lead time weeks before Rank 2 packaging supplier is offered to Customer. (p. 7)</li> <li>• Added reference to BR167 forward spec pricing horizontal. (pp. 7, 22)</li> <li>• Changed statement on preferred returnable packaging suppliers and added contact information. (p. 8)</li> </ul>  |

|                        |                     |   |
|------------------------|---------------------|---|
| <p>7<br/>Continued</p> | <p>31 July 2017</p> | <ul style="list-style-type: none"> <li>• Added statement for requirements for drawings of insert/dunnage of non-standard packaging and justification for. (p. 8)</li> <li>• Updated requirement Packaging ID label on all packaging. (p. 8)</li> <li>• Added fork pocket center to center dimensions. (p. 9)</li> <li>• Modified statement on advance notice for shipping in expendable packaging. (p. 10)</li> <li>• Modified statement that expendable box should mimic the ‘outer’ dimensions of the approved returnable. (p. 10)</li> <li>• Added statement for how bulk bin expendable box should be assembled. (p. 10)</li> <li>• Added expendable packaging codes. (pp. 11, 12)</li> <li>• Added list for when packaging are not suitable for shipping. (pp. 12-13)</li> <li>• Added additional statement for labels to be placed on Kennedy placard and old residue removed. (p. 13)</li> <li>• Updated reference to number of HU labels on each package. (p. 13)</li> <li>• Deleted reference to 4”x6” label size as all suppliers are switched to 3”x6” new label size. (p. 13)</li> <li>• Moved reference of Label Specifications to HU label size bullet point. (p. 13)</li> <li>• Added requirement that all HU labels must be adhesive backed and used in conjunction with a placard. (p. 13)</li> <li>• Added option for molded in placard for where the part identification label can be placed. (p. 13)</li> <li>• Clarified cardholder requirements for prior BR167 versus BR167 forward packaging. (p. 14)</li> <li>• Clarified Packaging Identification for prior BR167 versus BR167 forward packaging. (p. 14)</li> <li>• Added recommendation for Supplier to serialize all packaging to assist in packaging count verification at the Supplier’s docks. (pp. 15, 19)</li> <li>• Added RFID section. (p. 15)</li> <li>• Added illustration reference point for rack serial number. (p. 16)</li> <li>• Changed possible source for TPM sticker. (p. 16)</li> <li>• Modified statement for requirements for drawings of racks and justification for. (p. 17)</li> <li>• Changed wording from ‘are required to’ to ‘SHALL’. (pp. 17, 19, 20)</li> <li>• Added thickness gauge of kick plate. (p. 17)</li> <li>• Updated Body Shop Specifications to distinguish between Supplier and MBUSI responsible packaging. (p. 18)</li> <li>• Clarified what ‘packaging’ consists of. (p. 18)</li> <li>• Changed proof of order and receipt of packaging by T5 number and not part number. (p.18)</li> <li>• Deleted duplicate wording on statement dealing with receipt of unrepaired racks. (p. 19)</li> <li>• Added reference to Body Shop Defective “YELLOWTAG”. (pp.19, 23)</li> <li>• Added reference to Monoflo links for repair videos. (p. 19)</li> <li>• Added chargeback for Mixed Load / Master Label misuse or non-compliance to MBUSI standards. (p. 20)</li> <li>• Added deadline for TPM Report before chargeback is issued. (p. 20)</li> <li>• Added reference to new TPM Report Templates. (pp. 20, 22, 23)</li> <li>• Added statements regarding fleet calculation and factors affecting it. (p. 21)</li> <li>• Added statement for packaging fleet purchase documentation. (p. 20)</li> <li>• Added chargeback for non-submittal of drawings. (p 20)</li> <li>• Added chargeback for non-submittal of Acknowledgement Sheet. (p.20)</li> <li>• Changed statement to cover all future builds outside on the MBUSI facility. (p. 21)</li> <li>• Added T5 number to all Bulk Bin Supplier ID tags, Attachment B. (p. 34)</li> <li>• Changed ID tags to call for Supplier Ship to City, State versus Birmingham, AL and reduced height of “T5” to represent visual requirements. (p. 34)</li> <li>• Changed Attachment “B” BR167 forward packaging identification section to match updated requirements. (pp. 34-42)</li> <li>• Added Acknowledgement Sheet. (p. 46)</li> </ul> |
| <p>8</p>               | <p>4 Aug 2017</p>   | <ul style="list-style-type: none"> <li>• Added name for Rank 1 Packaging Supplier. (p. 6-7)</li> <li>• Clarified that prototype racks are to include all series level stenciling. (p. 9)</li> <li>• Corrected prototype paint color. (pp. 5, 9)</li> </ul>  |
| <p>9</p>               | <p>31 Aug 2017</p>  | <ul style="list-style-type: none"> <li>• Added Packaging code label on non-hot stamp short end of T5 524 series straight wall totes. (p.7)</li> </ul>   |

|                |             |   |
|----------------|-------------|---|
| 9<br>continued | 31 Aug 2017 | <ul style="list-style-type: none"> <li>• Added email address to send Requests for Use of Alternate Packaging Forms to. (p. 10)</li> <li>• Updated alternative expendable packaging codes. (p. 12)</li> <li>• Clarified JIT versus JIS on steel rack identification illustrations. (p. 17)</li> <li>• Modified wording to also cover non-compliant returnable packaging. (p. 21)</li> <li>• Deleted obsolete chargeback non-conformity. (p.21)</li> <li>• Corrected <a href="mailto:MBUSIPackaging@daimler.com">MBUSIPackaging@daimler.com</a> email address. (pp. 20, 47)</li> <li>• Updated pictures of new half bulk bin. (p.38)</li> <li>• Updated Supplier container codes. (pp. 41-43)</li> </ul>  |
| 10             | 19 Feb 2018 | <ul style="list-style-type: none"> <li>• Moved Acknowledgement Form notification statement from page 1 to the title page.</li> <li>• Added stencil color associated with racks. (pp. 5, 9)</li> <li>• Clarified JIT versus JIS rack coloring. (pp. 5, 9)</li> <li>• Updated dimensions for T554525 to reflect new design. (p. 6)</li> <li>• Clarified costs that Supplier is responsible for. (p. 7)</li> <li>• Added eCon Container Management section. (p. 9)</li> <li>• Corrected dimensions of expendable packaging and clarified what should be shown in the ASN and on the label. (p. 12)</li> <li>• Clarified RFID location for T552405 tote and extended length bulk bins. (p. 16)</li> <li>• Clarified what packaging does not have RFID tags. (p.16)</li> <li>• Clarified rack identification points. (p.17)</li> <li>• Corrected section title for Reference Documents. (p. 23)</li> <li>• Updated half bin picture with decorations and Supplier info. (p. 38)</li> <li>• Corrected Buckhorn extended length bulk bin drawings pictures and RFID locations. (pp. 40-41)</li> <li>• Corrected tote decorations. (p. 41-43)</li> <li>• Updated ESD hot stamp sizes for totes. (p. 41)</li> <li>• Updated Supplier code and pictures for ESD tote lids. (p. 44)</li> </ul> |

# MBUSI Packaging Specifications

## Destination – Vance, AL

### I. PACKAGING DATA FORM

All suppliers must complete and return the Packaging Data Form for every new part number, part number change, or packaging change prior to shipping production parts to MBUSI! Authorization from MBUSI Packaging Engineer/Specialist is required prior to deviating from the packaging on the approved form. Packaging Data Form is available on the Supplier Communication Guide website or directly from your MBUSI Packaging Contact.

### II. RETURNABLE PACKAGING SPECIFICATIONS – Prior to BR167

- In this document, the word “**SHALL**” indicates a requirement and the word “**SHOULD**” indicates a recommendation.
- NAFTA Suppliers are 100% responsible for procuring, cleaning costs and replacement costs of lost or damaged packaging. These costs **SHOULD** be clearly identified in the contracts with Mercedes-Benz Purchasing Department in Germany.
- MBUSI uses returnable packaging for delivery of parts with its suppliers. The aim is the consistent creation of a logistics chain with standard packaging and partnership-based use of the associated potential. Returnable packaging also makes a substantial contribution to the avoidance of waste. Returnable packaging includes modular or unit loads such as plastic totes, bulk knock downs, pallets, wire mesh baskets and unique packaging such as racks, carts, and vacuum-formed tray packs.
- The system of returnable packaging (excluding specially designed racks for unique parts) will consist of modules based on the 1143mm x 1219mm (45” x 48”) pallet. At present, MBUSI will accept the following:

#### Modular

| MBUSI Pack Code | Buckhorn Part Number | Packaging Color                  | O.D. Length [in/mm] | O.D. Width [in/mm] | O.D. Height [in/mm] | I.D. Length [in/mm] | I.D. Width [in/mm]  | I.D. Height [in/mm] | Weight [lbs./kg]   |
|-----------------|----------------------|----------------------------------|---------------------|--------------------|---------------------|---------------------|---------------------|---------------------|--------------------|
| T5 22405        | SW12070502           | Charcoal Gray w/ white lettering | 12 in.<br>305 mm    | 7.5 in.<br>191 mm  | 5.0 in.<br>127 mm   | 9.4 in.<br>239 mm   | 5.4 in.<br>137 mm   | 4.3 in.<br>109 mm   | 1.2 lbs.<br>0.5 kg |
| T5 21207        | SX151208A4           | Royal Blue w/ white lettering    | 15 in.<br>381 mm    | 12 in.<br>305 mm   | 7.5 in.<br>191 mm   | 13 in.<br>330 mm    | 9.38 in.<br>238 mm  | 6.38 in.<br>162 mm  | 2.8 lbs.<br>1.3 kg |
| T5 20607        | SX241508A4           | Green w/ white lettering         | 24 in.<br>610 mm    | 15 in.<br>381 mm   | 7.5 in.<br>191 mm   | 21.38 in.<br>543 mm | 13 in.<br>330 mm    | 6.38 in.<br>162 mm  | 4.6 lbs.<br>2.1 kg |
| T5 20609        | SX24151000           | Maroon w/ white lettering        | 24 in.<br>610 mm    | 15 in.<br>381 mm   | 9.5 in.<br>241 mm   | 21.38 in.<br>543 mm | 13 in.<br>330 mm    | 8.38 in.<br>213 mm  | 6.2 lbs.<br>2.8 kg |
| T5 20614        | SX24151500           | Orange w/ white lettering        | 24 in.<br>610 mm    | 15 in.<br>381 mm   | 14.5 in.<br>368 mm  | 21.38 in.<br>543 mm | 13 in.<br>330 mm    | 13.38 in.<br>340 mm | 7.6 lbs.<br>3.4 kg |
| T5 20407        | SX242208A4           | Light Blue w/ white lettering    | 24 in.<br>610 mm    | 22 in.<br>559 mm   | 7.5 in.<br>190.5 mm | 21.38 in.<br>543 mm | 20.38 in.<br>518 mm | 6.38 in.<br>162 mm  | 6.6 lbs.<br>3.0 kg |
| T5 20411        | SX242211A4           | Yellow w/ white lettering        | 24 in.<br>610 mm    | 22 in.<br>559 mm   | 11 in.<br>279 mm    | 21.38 in.<br>543 mm | 20.38 in.<br>518 mm | 9.88 in.<br>251 mm  | 8.0 lbs.<br>3.6 kg |
| T5 20414        | SX242215A4           | Grey w/ white lettering          | 24 in.<br>610 mm    | 22 in.<br>559 mm   | 14.5 in.<br>368 mm  | 21.38 in.<br>543 mm | 20.38 in.<br>518 mm | 13.38 in.<br>340 mm | 9.1 lbs.<br>4.1 kg |



**Modular - continued**

| MBUSI Pack Code | Buckhorn Part Number | Packaging Color                  | O.D. Length [in/mm] | O.D. Width [in/mm] | O.D. Height [in/mm]  | I.D. Length [in/mm]   | I.D. Width [in/mm]    | I.D. Height [in/mm]   | Weight [lbs./kg]     |
|-----------------|----------------------|----------------------------------|---------------------|--------------------|----------------------|-----------------------|-----------------------|-----------------------|----------------------|
| T5 23207        | SW32150802           | Dark Gray w/ white lettering     | 32 in.<br>813 mm    | 15 in.<br>381 mm   | 7.5 in.<br>191 mm    | 29.38 in.<br>746 mm   | 13 in.<br>330 mm      | 6.88 in.<br>175 mm    | 5.58 lbs.<br>2.53 kg |
| T5 20307        | SX48150800           | Charcoal Gray w/ white lettering | 48 in.<br>1219 mm   | 15 in.<br>381 mm   | 7.5 in.<br>191 mm    | 45.38 in.<br>1153 mm  | 13 in.<br>330 mm      | 6.38 in.<br>162 mm    | 8.9 lbs.<br>4.0 kg   |
| T5 71207        | SX151208A4VZ         | Black w/ yellow lettering        | 15 in.<br>381 mm    | 12 in.<br>304.8 mm | 7.5 in.<br>190.5 mm  | 13.13 in.<br>333.5 mm | 9.56 in.<br>242.8 mm  | 6.38 in.<br>162 mm    | 2.96 lbs.<br>1.34 kg |
| T5 70607        | SX241508A4VZ         | Black w/ yellow lettering        | 24 in.<br>609.6 mm  | 15 in.<br>381 mm   | 7.5 in.<br>190.5 mm  | 21.75 in.<br>552.4 mm | 13.25 in.<br>336.5 mm | 6.375 in.<br>161.9 mm | 4.85 lbs.<br>2.19 Kg |
| T5 70609        | SX24151000 VZ        | Black w/ yellow lettering        | 24 in.<br>609.6 mm  | 15 in.<br>381 mm   | 9.5 in.<br>241.3 mm  | 21.47 in.<br>545 mm   | 13.0 in.<br>330.2 mm  | 8.31 in.<br>211 mm    | 6.38 lbs.<br>2.89 kg |
| T5 70614        | SX24151500 VZ        | Black w/ yellow lettering        | 24 in.<br>609.6 mm  | 15 in.<br>381 mm   | 14.5 in.<br>368.3 mm | 21.50 in.<br>546.1 mm | 13.03 in.<br>331 mm   | 13.38 in.<br>340 mm   | 8.31 lbs.<br>3.77 kg |
| T5 70407        | SX242208A4VZ         | Black w/ yellow lettering        | 24 in.<br>609.6 mm  | 22 in.<br>559 mm   | 7.5 in.<br>190.5 mm  | 21.38 in.<br>543 mm   | 20.38 in.<br>518 mm   | 6.38 in.<br>162 mm    | 6.9 lbs.<br>3.1 kg   |

**Unit Load:**

| MBUSI Pack Code | Buckhorn Part Number             | Packaging Color          | O.D. Length [in/mm]  | O.D. Width [in/mm] | O.D. Height [in/mm] | I.D. Length [in/mm] | I.D. Width [in/mm]  | I.D. Height [in/mm] | Weight [lbs./kg]     |
|-----------------|----------------------------------|--------------------------|----------------------|--------------------|---------------------|---------------------|---------------------|---------------------|----------------------|
| T5 64228        | BF42292800<br>(with fork straps) | Black w/ white lettering | 42 in.<br>1067 mm    | 29 in.<br>732 mm   | 28 in.<br>706 mm    | 39.4 in.<br>1001 mm | 26.6 in.<br>676 mm  | 22.7 in.<br>577 mm  | 70.4 lbs.<br>32 kg   |
| T5 60125        | BN484525<br>2 door               | Black w/ white lettering | 48 in.<br>1219 mm    | 45 in.<br>1143 mm  | 25 in.<br>635 mm    | 44.5 in.<br>1130 mm | 41.5 in.<br>1054 mm | 18 in.<br>457 mm    | 149 lbs.<br>68 kg    |
| T5 60134        | BN484534<br>2 door               | Black w/ white lettering | 48 in.<br>1219 mm    | 45 in.<br>1143 mm  | 34 in.<br>864 mm    | 44.5 in.<br>1130 mm | 41.5 in.<br>1054 mm | 27 in.<br>686 mm    | 159 lbs.<br>72 kg    |
| T5 60140        | BX484540<br>2 door               | Black w/ white lettering | 48 in.<br>1219 mm    | 45 in.<br>1143 mm  | 40 in.<br>1016 mm   | 44.5 in.<br>1130 mm | 41.5 in.<br>1054 mm | 33 in.<br>838 mm    | 183 lbs.<br>83 kg.   |
| T5 60144        | BX454844<br>2 door               | Black w/ white lettering | 48 in.<br>1219 mm    | 45 in.<br>1143 mm  | 44 in.<br>1118 mm   | 44.5 in.<br>1130 mm | 41.5 in.<br>1054 mm | 37 in.<br>940 mm    | 200 lbs.<br>90.7 kg  |
| T5 60150        | BX484550<br>2 door               | Black w/ white lettering | 48 in.<br>1219 mm    | 45 in.<br>1143 mm  | 50 in.<br>1270 mm   | 44.5 in.<br>1130 mm | 41.5 in.<br>1054 mm | 43 in.<br>1092 mm   | 224 lbs.<br>102 kg   |
| T5 65725        | BS574825<br>4 door               | Black w/ white lettering | 57.25 in.<br>1454 mm | 48 in.<br>1219 mm  | 25 in.<br>635 mm    | 53.5 in.<br>1359 mm | 44.5 in.<br>1130 mm | 17.6 in.<br>447 mm  | 144 lbs.<br>65.3 kg  |
| T5 65734        | BS574834<br>4 door               | Black w/ white lettering | 57.25 in.<br>1454 mm | 48 in.<br>1219 mm  | 34 in.<br>864 mm    | 53.5 in.<br>1359 mm | 44.5 in.<br>1130 mm | 26.6 in.<br>676 mm  | 173 lbs.<br>78.5 kg  |
| T5 66425        | BS644825<br>4 door               | Black w/ white lettering | 64.5 in.<br>1638 mm  | 48 in.<br>1219 mm  | 25 in.<br>635 mm    | 60.8 in.<br>1544 mm | 44.5 in.<br>1130 mm | 17.6 in.<br>447 mm  | 157 lbs.<br>71 kg    |
| T5 66434        | BS644834<br>4 door               | Black w/ white lettering | 64.5 in.<br>1638 mm  | 48 in.<br>1219 mm  | 34 in.<br>864 mm    | 60.8 in.<br>1544 mm | 44.5 in.<br>1130 mm | 26.6 in.<br>676 mm  | 183 lbs.<br>83 kg    |
| T5 66444        | BS644844<br>4 door               | Black w/ white lettering | 64.5 in.<br>1638 mm  | 48 in.<br>1219 mm  | 44 in.<br>1118 mm   | 60.8 in.<br>1544 mm | 44.5 in.<br>1130 mm | 36.6 in.<br>930 mm  | 226 lbs.<br>102.5 kg |
| T5 66450        | BS644850<br>4 door               | Black w/ white lettering | 64.5 in.<br>1638 mm  | 48 in.<br>1219 mm  | 50 in.<br>1270 mm   | 60.8 in.<br>1544 mm | 44.5 in.<br>1130 mm | 46.6 in.<br>1184 mm | 244 lbs.<br>110.7 kg |
| T5 67025        | BS704825<br>4 door               | Black w/ white lettering | 70 in.<br>1778 mm    | 48 in.<br>1219 mm  | 25 in.<br>635 mm    | 66.3 in.<br>1684 mm | 44.5 in.<br>1130 mm | 17.6 in.<br>447 mm  | 179 lbs.<br>81.2 kg  |
| T5 67034        | BS704834<br>4 door               | Black w/ white lettering | 70 in.<br>1778 mm    | 48 in.<br>1219 mm  | 34 in.<br>864 mm    | 66.3 in.<br>1684 mm | 44.5 in.<br>1130 mm | 26.6 in.<br>676 mm  | 205 lbs.<br>93 kg    |
| T5 67044        | BS704844<br>4 door               | Black w/ white lettering | 70 in.<br>1778 mm    | 48 in.<br>1219 mm  | 44 in.<br>1118 mm   | 66.3 in.<br>1684 mm | 44.5 in.<br>1130 mm | 36.6 in.<br>930 mm  | 246 lbs.<br>111.6 kg |
| T5 67050        | BS704850<br>4 door               | Black w/ white lettering | 70 in.<br>1778 mm    | 48 in.<br>1219 mm  | 50 in.<br>1270 mm   | 66.3 in.<br>1684 mm | 44.5 in.<br>1130 mm | 46.6 in.<br>1184 mm | 269 lbs.<br>122 kg   |

**Pallets/Top Caps/Lids:**

| MBUSI Pack Code    | Buckhorn Part Number            | Packaging Color           | O.D. Length [in/mm] | O.D. Width [in/mm] | O.D. Height [in/mm] | I.D. Length [in/mm] | I.D. Width [in/mm]  | I.D. Height [in/mm] | Weight [lbs./kg]   |
|--------------------|---------------------------------|---------------------------|---------------------|--------------------|---------------------|---------------------|---------------------|---------------------|--------------------|
| T5 50102 (Top Cap) | TV48450300                      | Black w/ white lettering  | 49 in.<br>1245 mm   | 46 in.<br>1168 mm  | 3 in.<br>76 mm      | 48.5 in.<br>1232 mm | 45.5 in.<br>1156 mm |                     | 15 lbs.<br>7 kg    |
| T5 50106 (Pallet)  | PM48450600                      | Black w/ white lettering  | 48 in.<br>1219 mm   | 45 in.<br>1143 mm  | 6 in.<br>152 mm     | 47.5 in.<br>1207 mm | 44.5 in.<br>1130 mm |                     | 38 lbs.<br>17 kg   |
| T5 50712           | SL15120100VZ001 (ESD T5712 lid) | Black w/ yellow lettering | 15 in.<br>381 mm    | 12 in.<br>305 mm   | 0.4 in.<br>10.2 mm  |                     |                     |                     | 0.7 lbs.<br>0.3 kg |
| T5 50706           | SL24150100VZ001 (ESD T5706 lid) | Black w/ yellow lettering | 24 in.<br>610 mm    | 15 in.<br>381 mm   | 0.4 in.<br>10.2 mm  |                     |                     |                     | 1.4 lbs.<br>0.6 kg |
| T5 50704           | SL24220100VZ001 (ESD T5704 lid) | Black w/ yellow lettering | 24 in.<br>610 mm    | 22 in.<br>561 mm   | 0.6 in.<br>15.2 mm  |                     |                     |                     | 1.9 lbs.<br>0.9 kg |

- No die stamp charges for MBUSI specified hot stamps.
- **Artwork:** **Setup charge of \$30.00 for new artwork only applies to Supplier ID labels, Supplier ID tags, Special Dunnage ID labels, and Special Dunnage ID tags. (See Attachment “A” and Reference Documents SCGPA03, SCGPA04, SCGPA05, and SCGPA15)** To expedite order process, Buckhorn can begin artwork approval process in advance of purchase order if customer supplies details. Artwork charge will be applied once purchase order is received.
- Pricing is on a contract with MBUSI. Buckhorn will not give a discount from this pricing to dealers or dunnage houses.
- T5 224 series straight wall tote price includes one (1) 6.5” x 4.5” Kennedy Label Placards, located on one (1) long side, (Buckhorn part number 04ACLBPK00109); one (1) plastic card holder, located on long side opposite the Placard (Buckhorn part number 04ACCH029483C00); one (1) hot stamp of specified MBUSI information located on one short end; and two (2) 3” x 1” vinyl Supplier labels per MBUSI specs, one (1) on each side short end.
- All series straight wall tote prices includes:
  - two (2) 6.5” x 4.5” Kennedy Label Placards (Buckhorn part number 04ACLBPK00109) located on one (1) sides and one (1) end;
  - Two (2) plastic card holders, located on opposite side and end from Placard:
    - T5 212, T5 712, T5 20607, T5 70607, T5 204 and T5 704 = Buckhorn part number 0804CHMX02;
    - T5 20609, T5 70609, T5 20614, T5 70614, T5 203, and T5 232 = Buckhorn part number 0804CHMX04;
  - one (1) hot stamp of specified MBUSI information located on end, behind cardholder, on opposite side from Placard; and
  - four (4) 3” x 1” vinyl Supplier labels per MBUSI specs, one (1) on each side and end.
- Bulk bin price includes installation for four (4) molded placards (Buckhorn part number 0604PDMXP126000) on both long and short sides; and four (4) 6.5” x 3” silk screened Supplier ID tags on base, attached in recessed areas using self-tapping screws.
- Pallet and top cap meet required specs. Pallet price includes molding of specified MBUSI information into the top of each pallet. Top Cap price includes a hot stamp of specified MBUSI information on one (1) 48” side.
- It is the Suppliers responsibility to notify and order from Buckhorn a second (2<sup>nd</sup>) label to identify the special packaging code that is assigned by the MBUSI Packaging Engineer/Specialist for all hand held totes and bulk bins which will include inserts/dunnage. (Reference Attachment “A”)
- Replacement labels, tags, placards and cardholders: Contact the preferred returnable packaging supplier for agreed upon MBUSI pricing.
- Supplier is responsible for shipping costs.
- The number 7 after the T5 within the packaging code signifies the packaging is ESD.

- MBUSI's preferred returnable packaging supplier is: "Buckhorn, Inc." (Milford, OH) for all returnable tote/pallet systems, bulk bins, pallets and top caps. Buckhorn has sales representatives for all Tier 1 Suppliers. These sales representatives are at your disposal to help you evaluate the needed packaging size, inserts/dunnage, etc. For assistance, the main Buckhorn number is (800) 543-4454.

MBUSI has standardized packaging pricing. Using a single-source Supplier enables our Suppliers to take advantage of volume discounts, maintain common standards, and keep the packaging investment to a minimum. (Reference Document SCGPA07, Buckhorn specs pricing horizontal)

- All orders placed with Buckhorn will be made through the Customer Service Coordinator for the Supplier's location. Buckhorn can be reached by calling (800) 543-4454.
- It is the responsibility of the Supplier to choose the packaging type and inserts/dunnage that is most suitable for maintaining the part quality. MBUSI Packaging Engineer/Specialist may propose packaging that will work best within the plants. Part damage related to packaging is the Supplier's responsibility, regardless of who designs or approves the packaging. The quantity per package and part configuration must be agreed upon between MBUSI and the Supplier. **Internal delivery philosophy is to maintain enough parts in the packaging to support a minimum of 15 min. for hand held totes and a minimum of 30 min. for bulk bin and racks.**
- If a part has been identified as being ESD Sensitive then both the packaging and inserts/dunnage must comply with the requirements of having a surface resistance to ground of less than one (1) GigaOhm (7.5 x 10 to 5th power <= Rg <= 1 x 10 to the 9th power). Questions are to be directed to the responsible MBUSI Packaging Engineer/Specialist. Reference standard EN 61340-5 1&2:2001 or whatever the newest version is. This is an international specification that is mainly used in Europe. The USA uses ANSI standards for ESD.
- Final packaging approval by MBUSI Packaging Group is required before Suppliers place any packaging orders, begin using any packaging, or ship any packages to MBUSI. MBUSI Packaging Group reserves the right to reject or refuse the use of any packaging supplier. In the case of packaging/rack orders, this ensures that the pricing quoted to the individual supplier is correct and the receipt timing of the packaging purchased is appropriate for MBUSI's needs. The Purchasing Department in Germany, must review and approve all costs prior to packaging being purchased. No packaging can be accepted without an approved Packaging Data Form (PDF) on file.
- In an effort to reduce handling of parts and returnable inserts/dunnage MBUSI encourages the minimization of the number of dunnage layers per tote while maintaining the maximum pack density and supporting the internal delivery philosophy. Bottom layer **SHALL** be secured to the packaging in order to minimize any losses, unless directed by the MBUSI Packaging Engineer/Specialist.
- **It is the Suppliers responsibility to notify and order from Buckhorn a second (2<sup>nd</sup>) label to identify the special packaging code that is assigned by the MBUSI Packaging Engineer/Specialist for all hand held totes and bulk bins which will include inserts/dunnage. This label is to be attached to all sides of the packaging. Without this proper identification, the packaging may not be referenced correctly on the returning Bill of Lading. This special label/tag will have a onetime artwork charge of \$30.00 per design. (See Attachment "A" and Reference Documents SCGPA03, SCGPA04, SCGPA05, and SCGPA15)**
- Specially designed part racks **SHOULD** try to maintain at least one dimension (length or width) equal to 1219 mm or 2438.4 mm (48" or 96") to maximize trailer utilization. Height **SHOULD** not exceed 1320.8 mm (52"), including rack stacking pins), in order to double stack material in the trucks, unless authorized by MBUSI Packaging Engineer/Specialist.

- Current approved assembly rack colors are as follows. Stencil color is white.  
Black (TriCorn Black, SW6258) for HU (JIT) Racks  
Burgundy (Burgundy, SW6300) for In-House Sequencing Racks  
Royal Blue (Loyal Blue, SW6510) for MLC (MBUSI Logistics Center) Racks  
Green (Arugula, SW6446) for Racks Sequenced by the Supplier (JIS)
- Any other colors will be mutually agreed upon with MBUSI Packaging Engineer/Specialist. Rack bases and top 1” of vertical corners will be painted yellow to assist material handlers at the Suppliers, at MBUSI, and at associated warehouses with fork placement and to ultimately reduce damage to racks.
- Prototype Racks will be painted yellow unless otherwise approved between the Supplier and the Packaging Engineer/Specialist. The paint code is Sherwin Williams Safety Yellow, SW4084 or RAL#1023.
- All production parts must be palletized in a way to allow handling by industrial forklift trucks unless otherwise accepted by MBUSI Packaging Engineer/Specialist. Pallets must be accessible from all four sides.
- The gross weight of any palletized unit must not exceed 818 Kgs (1800 lbs.) unless otherwise accepted by MBUSI Packaging Engineer/Specialist.
- Palletized unit loads **SHALL** require stretch wrap to secure the complete load, including pallet and lid that is approved by MBUSI Packaging Engineer/Specialist. For shipments of heavy parts, as directed by MBUSI Packaging Engineer/Specialist, stretch wrap and banding (plastic or nylon) is required. For safety reasons, steel banding is not acceptable.
- Palletized unit loads must be stacked in transit; therefore, must not exceed 1320mm (52”) in height.
- All packages and palletized loads must be stackable unless part configuration and weight are prohibitive. This packaging must be agreed upon between the Supplier and MBUSI Packaging Engineer/Specialist.
- **MBUSI returnable packaging are to be used by the Tier 1 Supplier for finished goods only. Requirements for additional packaging to be used for equipment optimization, external processes, etc. will be the responsibility of the Supplier even if the packaging is identical to the production packaging.**
- There **SHALL** be no use of any materials within the returnable or expendable packaging containing silicone.

### III. RETURNABLE PACKAGING SPECIFICATIONS – BR167 and future projects

- In this document, the word “**SHALL**” indicates a requirement and the word “**SHOULD**” indicates a recommendation.
- NAFTA Suppliers are 100% responsible for procuring, cleaning costs and replacement costs of lost or damaged packaging. These costs **SHOULD** be clearly identified in the contracts with Mercedes-Benz Purchasing Department in Germany.
- MBUSI uses returnable packaging for delivery of parts with its suppliers. The aim is the consistent creation of a logistics chain with standard packaging and partnership-based use of the associated potential. Returnable packaging also makes a substantial contribution to the avoidance of waste. Returnable packaging includes

modular or unit loads such as plastic totes, bulk knock downs, pallets, wire mesh baskets and unique packaging such as racks, carts, and vacuum-formed tray packs.

- All ESD packaging **SHALL** have an ESD protective lid whether it is a build in lid or a returnable lid that attaches to the package. This is to prevent potential ESD shock damage to the parts during staging or movement.
- All non-ESD **special** returnable totes are to be **Orange** in color unless directed by the MBUSI Packaging Engineer/Specialist.
- Returnable totes and bulk bins that were used on any 164/251/166/205/292 project **SHALL** not be used on the BR167 project forward.
- The system of returnable packaging (excluding specially designed racks for unique parts) will consist of modules based on the 1143mm x 1219mm (45" x 48") pallet. At present, MBUSI will accept the following:

**Modular:**

| MBUSI Packaging Code Current                        | Rank 1 Supplier Name | O.D. Length [in/mm]   | O.D. Width [in/mm]    | O.D. Height [in/mm]   | I.D. Length [in/mm]   | I.D. Width [in/mm]    | I.D. Height* [in/mm]  | Weight [kg/lbs.]     |
|---|----------------------|-----------------------|-----------------------|-----------------------|-----------------------|-----------------------|-----------------------|----------------------|
| T5 52405<br>Dark Grey w/white lettering             | SCHAEFER             | 12 in.<br>305 mm.     | 7.4 in.<br>187.96 mm  | 5.0 in.<br>127 mm     | 9.3 in.<br>236.22 mm  | 5.3 in.<br>134.62 mm  | 4.3 in.<br>109 mm     | 1.3 lbs.<br>0.59 kg  |
| T5 57405<br>ESD Conductive Black w/yellow lettering | SCHAEFER             | 12 in.<br>305 mm.     | 7.4 in.<br>187.96 mm  | 5.0 in.<br>127 mm     | 9.3 in.<br>236.22 mm  | 5.3 in.<br>134.62 mm  | 4.3 in.<br>109 mm     | 1.3 lbs.<br>0.59 kg  |
| T5 51207<br>Royal Blue w/white lettering            | SCHAEFER             | 14.9 in.<br>378.46 mm | 11.9 in.<br>302.26 mm | 7.5 in.<br>191 mm     | 13.1 in.<br>332.74 mm | 9.5 in.<br>241.3 mm   | 6.9 in.<br>175.26 mm  | 2.2 lbs.<br>1.0 kg   |
| T5 57207<br>ESD Conductive Black w/yellow lettering | SCHAEFER             | 14.9 in.<br>378.46 mm | 11.9 in.<br>302.26 mm | 7.5 in.<br>191 mm     | 13.1 in.<br>332.74 mm | 9.5 in.<br>241.3 mm   | 6.9 in.<br>175.26 mm  | 2.23 lbs.<br>1.01 kg |
| T5 51211<br>Yellow w/white lettering                | SCHAEFER             | 14.9 in.<br>378.46 mm | 11.9 in.<br>302.26 mm | 10.9 in.<br>276.86 mm | 13.1 in.<br>332.74 mm | 9.1 in.<br>231.14 mm  | 10.3 in.<br>262 mm    | 2.8 lbs.<br>1.27 kg  |
| T5 57211<br>ESD Conductive Black w/yellow lettering | SCHAEFER             | 14.9 in.<br>378.46 mm | 11.9 in.<br>302.26 mm | 10.9 in.<br>276.86 mm | 13.1 in.<br>332.74 mm | 9.1 in.<br>231.14 mm  | 10.3 in.<br>262 mm    | 2.85 lbs.<br>1.29 kg |
| T5 50607<br>Green w/white lettering                 | SCHAEFER             | 23.9 in.<br>607.06 mm | 14.9 in.<br>378.46 mm | 7.5 in.<br>191 mm     | 21.5 in.<br>546.1 mm  | 13.1 in.<br>332.74 mm | 6.9 in.<br>175.26 mm  | 3.4 lbs.<br>1.54 kg  |
| T5 57607<br>ESD Conductive Black w/yellow lettering | SCHAEFER             | 23.9 in.<br>607.06 mm | 14.9 in.<br>378.46 mm | 7.5 in.<br>191 mm     | 21.5 in.<br>546.1 mm  | 13.1 in.<br>332.74 mm | 6.9 in.<br>175.26 mm  | 4.5 lbs.<br>2.04 kg  |
| T5 50611<br>Light Blue w/white lettering            | SCHAEFER             | 23.9 in.<br>607.06 mm | 14.9 in.<br>378.46 mm | 10.9 in.<br>276.86 mm | 21.5 in.<br>546.1 mm  | 13.1 in.<br>332.74 mm | 10.3 in.<br>261.62 mm | 4.8 lbs.<br>2.18 kg  |
| T5 57611<br>ESD Conductive Black w/yellow lettering | SCHAEFER             | 23.9 in.<br>607.06 mm | 14.9 in.<br>378.46 mm | 10.9 in.<br>276.86 mm | 21.5 in.<br>546.1 mm  | 13.1 in.<br>332.74 mm | 10.3 in.<br>261.62 mm | 5.1 lbs.<br>2.31 kg  |

**Unit Load:**

| MBUSI Packaging Code Current                     | Rank 1 Supplier Name | O.D. Length [in/mm] | O.D. Width [in/mm]    | O.D. Height [in/mm]   | I.D. Length [in/mm]   | I.D. Width [in/mm]  | I.D. Height* [in/mm] | Weight [kg/lbs.]       |
|--|----------------------|---------------------|-----------------------|-----------------------|-----------------------|---------------------|----------------------|------------------------|
| T5 54525<br>Black w/ white lettering, blue bases | MONOFLO              | 44.5 in.<br>1130 mm | 24 in.<br>610 mm      | 25 in.<br>635 mm      | 41 in.<br>1041.4 mm   | 21 in.<br>533.4 mm  | 18.4 in.<br>467.4 mm | 66 lbs.<br>29.9 kg     |
| T5 50125<br>Black w/ white lettering, blue bases | MONOFLO              | 48 in.<br>1219 mm   | 45 in.<br>1143 mm     | 25.2 in.<br>640.08 in | 44.5 in.<br>1130.3 mm | 41.5 in.<br>1054 mm | 18.5 in.<br>469.9 mm | 101 lbs.<br>45.81 kg   |
| T5 50134<br>Black w/ white lettering, blue bases | MONOFLO              | 48 in.<br>1219 mm   | 44.5 in.<br>1130.3 mm | 33.8 in.<br>858.52 mm | 44.5 in.<br>1130 mm   | 41.5 in.<br>1054 mm | 27 in.<br>686 mm     | 118.0 lbs.<br>53.52 kg |
| T5 56425<br>Black w/ white lettering, blue bases | BUCKHORN             | 64.5 in.<br>1638 mm | 48 in.<br>1219 mm     | 25 in.<br>635 mm      | 60.8 in.<br>1544 mm   | 44.5 in.<br>1130 mm | 17.6 in.<br>447 mm   | 157 lbs.<br>71 kg      |
| T5 56434<br>Black w/ white lettering, blue bases | BUCKHORN             | 64.5 in.<br>1638 mm | 48 in.<br>1219 mm     | 34 in.<br>864 mm      | 60.8 in.<br>1544 mm   | 44.5 in.<br>1130 mm | 26.6 in.<br>676 mm   | 183 lbs.<br>83 kg      |

**Pallets/Top Caps/Lids:**

| MBUSI Packaging Code Current                             | Rank 1 Supplier Name | O.D. Length [in/mm] | O.D. Width [in/mm] | O.D. Height [in/mm] | I.D. Length [in/mm]  | I.D. Width [in/mm]    | I.D. Height* [in/mm] | Weight [kg/lbs.]    |
|--|----------------------|---------------------|--------------------|---------------------|----------------------|-----------------------|----------------------|---------------------|
| T5 50102<br>Black w/ white lettering blue stripe         | BUCKHORN             | 49 in.<br>1245 mm   | 46 in.<br>1168 mm  | 3 in.<br>76 mm      | 48.5 in.<br>1232 mm  | 45.5 in.<br>1156 mm   | N/A                  | 15 lbs.<br>7 kg     |
| T5 50106<br>Black w/ white lettering                     | BUCKHORN             | 48 in.<br>1219 mm   | 45 in.<br>1143 mm  | 6 in.<br>152 mm     | 47.5 in.<br>1207 mm  | 44.5 in.<br>1130 mm   | N/A                  | 38 lbs.<br>17.2 kg  |
| T5 50712<br>ESD Conductive Black Lid w/ yellow lettering | SCHAEFER             | 15 in.<br>381 mm    | 12 in.<br>304.8 mm | N/A<br>10.2 mm      | 13.3 in.<br>337.8 mm | 10.3 in.<br>261.6 mm  | N/A                  | 0.6 lbs.<br>0.27 kg |
| T5 50706<br>ESD Conductive Black Lid w/ yellow lettering | SCHAEFER             | 24 in.<br>609.6 mm  | 15 in.<br>381 mm   | N/A<br>10.2 mm      | 22.3 in.<br>566.4 mm | 13.75 in.<br>349.3 mm | N/A                  | 0.7 lbs.<br>0.32 kg |

- No die stamp charges for MBUSI specified hot stamps.
- **Artwork:** **Setup charge for new artwork is included in the packaging price. (See Attachment “B” and Reference Documents SCGPA05, SCGPA19, SCGPA20, SCGPA21, SCGPA22, SCGPA23, and SCGPA24)** To expedite order process, our Approved Packaging Suppliers can begin artwork approval process in advance of purchase order if customer supplies details.
- Pricing is on a contract with MBUSI. Our Approved Packaging Suppliers will not give a discount from this pricing to dealers or dunnage houses.
- T5 524 series straight wall tote price includes:
  - one (1) 6.5” x 3.5” Kennedy Label Placard, located on one (1) long side;
  - one (1) hot stamp of specified MBUSI information located on one short end;
  - one (1) packaging code label, located on non-hot stamp short end;
  - one (1) passive 4.125” x 0.75” RFID tag located on the hot stamp end; and
  - two (2) 3” x 1” vinyl Supplier labels per MBUSI specs, one (1) on each short end.
- All series straight wall tote prices includes:
  - two (2) 6.5” x 3.5” Kennedy Label Placards located on one (1) sides and one (1) end;
  - one (1) hot stamp of specified MBUSI information located on short end opposite side from Placard;
  - four (4) 3” x 1” vinyl Supplier labels per MBUSI specs, one (1) on each side and end.
  - one (1) passive 4.125” x 0.75” RFID tag, located on the hot stamp end; and
  - three (3) packaging code labels, located on all sides except the hot stamp side.
- Bulk bin price includes installation for
  - four (4) molded placards on each long and short sides;
  - four (4) 6.0” x 2.0” silk screened Supplier ID tags on base of each side, attached in recessed areas using adhesive and self-tapping screws and
  - one (1) passive 3.0” x 2.25” RFID tag, located on one (1) short end in recessed area.
- Pallet and top cap meet required specs. Pallet price includes molding of specified MBUSI information into the top of each pallet. Top Cap price includes a hot stamp of specified MBUSI information on one (1) 48” side. No RFID tags will be included.
- Replacement labels, tags, and placards: Contact the preferred returnable packaging Supplier for agreed upon MBUSI pricing.
- Supplier is responsible for all Shipping and Handling costs.
- The number 57 after the T5 within the packaging code signifies the package is ESD.

MBUSI’s has been able to negotiate standardized packaging pricing with all of the Approved Packaging Suppliers. This will enable our Suppliers to take advantage of volume discounts, maintain common standards, and keep the packaging investment to a minimum. **If the Packaging Supplier cannot meet or beat a 6 week**



**lead time then the MBUSI Packaging Engineer/Specialist can be contacted for assistance or another source and negotiated price.** (Reference Document SCGPA18)

- Each Approved Packaging Supplier will have a sales representatives for all Tier 1 Suppliers. These sales representatives are at your disposal to help you evaluate the needed packaging size, inserts/dunnage, etc.
  - Buckhorn – District Sales Manager (615) 606-8552
  - Schaefer – Customer Service (704) 944-4500 Ext 3555 or Regional Sales Manager (980) 253-4850
  - Monoflo – Southeast Regional Sales Manager (540) 336-0410
- It is the responsibility of the Supplier to choose the packaging type and inserts/dunnage that is most suitable for maintaining the part quality. MBUSI Packaging Engineer/Specialist may propose packaging that will work best within the plants. Part damage related to packaging is the Supplier's responsibility, regardless of who designs or approves the packaging. The quantity per package and part configuration must be agreed upon between MBUSI and the Supplier. **Internal delivery philosophy is to maintain enough parts in the packaging to support a minimum of 15 min. for hand held totes and a minimum of 30 min. for bulk bin and racks.**
- **All Suppliers SHALL supply MBUSI with the most current drawings of the insert/dunnage or non-standard packaging. This will provide MBUSI with the capability of determining, in advance, the impact to production and delivery methods (i.e. AGV, ATLS, installation point change, etc.) It is still the responsibility of the Supplier to verify if new parts will fit into the packaging or if new packaging will be needed. Daimler CAD format is preferred but PDF is acceptable. Daimler Share Point SHALL be used as the only means of information exchange when 15MB data is exceeded. Less than 15MB can be sent via email. Contact the MBUSI Packaging Engineer/Specialist for access directions.**
- If a part has been identified as being ESD Sensitive then both the package and inserts/dunnage must comply with the requirements of having a surface resistance to ground of less than one (1) GigaOhm ( $7.5 \times 10$  to  $5^{\text{th}}$  power  $\leq R_g \leq 1 \times 10$  to the 9th power). Questions are to be directed to the responsible MBUSI Packaging Engineer/Specialist. Reference standard EN 61340-5 1&2:2001 or whatever the newest version is. This is an international specification that is mainly used in Europe. The USA uses ANSI standards for ESD.
- Final packaging approval by MBUSI Packaging Group is required before Suppliers place any packaging orders, begin using any packaging, or ship any packages to MBUSI. MBUSI Packaging Group reserves the right to reject or refuse the use of any packaging supplier. In the case of packaging/rack orders, this ensures that the pricing quoted to the individual supplier is correct and the receipt timing of the packaging purchased is appropriate for MBUSI's needs. The Purchasing Department in Germany, must review and approve all costs prior to packaging being purchased. No packaging can be accepted without an approved Packaging Data Form (PDF) on file.
- In an effort to reduce handling of parts and returnable inserts/dunnage MBUSI encourages the minimization of the number of dunnage layers per tote while maintaining the maximum pack density and supporting the internal delivery philosophy. Bottom layer **SHALL** be secured to the packaging in order to minimize any losses, unless directed by the MBUSI Packaging Engineer/Specialist.
- **It is the Suppliers responsibility to notify and order from one of our Approved Packaging Suppliers a label/tag with the corresponding packaging code that is assigned by the MBUSI Packaging Engineer/Specialist. This labeling will be for all hand held totes, trays and bulk bins whether or not it will include inserts/dunnage. This label is to be attached to all sides of the package. Without this proper identification, the packaging may not be referenced correctly on the returning Bill of Lading. (See Attachment "B" and Reference Documents SCGPA20, SCGPA21, SCGPA22, and SCGPA23)**

- Specially designed part racks **SHOULD** try to maintain at least one dimension (length or width) equal to 1219 mm or 2438.4 mm (48” or 96”) to maximize trailer utilization. Height **SHOULD** not exceed 1320.8 mm (52”), including rack stacking pins), in order to double stack material in the trucks, unless authorized by MBUSI Packaging Engineer/Specialist. Fork pocket opening **SHALL** not exceed 30 inch center to center dimensions.
- Current approved assembly rack colors are as follows. Stencil color is white.
  - Black (TriCorn Black, SW6258) for HU (JIT) Racks
  - Burgundy (Burgundy, SW6300) for In-House Sequencing Racks
  - Royal Blue (Loyal Blue, SW6510) for MLC (MBUSI Logistics Center) Racks
  - Green (Arugula, SW6446) for Racks Sequenced by the Supplier (JIS)
- Any other colors will be mutually agreed upon with MBUSI Packaging Engineer/Specialist. Rack bases and top 1” of vertical corners will be painted yellow to assist material handlers at the Suppliers, at MBUSI, and at associated warehouses with fork placement and to ultimately reduce damage to racks.
- Prototype Racks will be painted yellow with black stenciling and include all series intent stenciling unless otherwise approved between the Supplier and the Packaging Engineer/Specialist. The paint code is Sherwin Williams Safety Yellow, SW4084 or RAL#1023.
- All production parts must be palletized in a way to allow handling by industrial forklift trucks unless otherwise accepted by MBUSI Packaging Engineer/Specialist. Pallets must be accessible from all four sides.
- The gross weight of any palletized unit must not exceed 818 Kgs (1800 lbs.) unless otherwise accepted by MBUSI Packaging Engineer/Specialist.
- Palletized unit loads **SHALL** require stretch wrap to secure the complete load, including pallet and lid that is approved by MBUSI Packaging Engineer/Specialist. For shipments of heavy parts, as directed by MBUSI Packaging Engineer/Specialist, stretch wrap and banding (plastic or nylon) is required. For safety reasons, steel banding is not acceptable.
- Palletized unit loads must be stacked in transit; therefore, must not exceed 1320mm (52”) in height.
- All packages and palletized loads must be stackable unless part configuration and weight are prohibitive. This packaging must be agreed upon between the Supplier and MBUSI Packaging Engineer/Specialist.
- **MBUSI returnable packaging are to be used by the Tier 1 Supplier for finished goods only. Requirements for additional packaging to be used for equipment optimization, external processes, etc. will be the responsibility of the Supplier even if the packaging is identical to the production packaging.**
- There **SHALL** be no use of any materials within the returnable or expendable packaging containing silicone.

#### IV. eCon CONTAINER MANAGEMENT

- Supplier access to eCon via Covisint is now available.
- In the beginning only the functions Container Master Data and Packaging Plan are available.
- After V167 SOP, it is planned that quantity information will begin to be populated.



## V. EXPENDABLE PACKAGING

- Noncompliance with this requirement **SHALL** result in a chargeback for non-approved packaging.
- Expendable packaging (including expendable inserts/dunnage) is to be used only in exceptional cases. Expendable use requires prior written acceptance from the MBUSI Logistics Packaging Engineer/Specialist and as a general rule **SHOULD** be avoided.
- Reference Document SCGPA 11 when requesting by part number the use of alternate packaging. Blanket authorization will only be approved under very strict and specific circumstances. Failure to submit a completed form prior to shipment **SHALL** result in a chargeback. **A minimum of 48 hours advance notice SHOULD be given on notices of when packaging is running low. A minimum of 24 hours advance notice, prior to shipping, SHALL be given for requesting authorization to use alternate packaging.** The Request for Use of Alternate Packaging Form **SHOULD** be emailed to [MBUSIPackaging@daimler.com](mailto:MBUSIPackaging@daimler.com).
- Expendable packaging as a backup is required for emergency situations when returnable packaging is not available.
- Expendable packaging **SHALL** mirror the outer dimensions of the approved returnable in size, inserts/dunnage, and density. If returnable packaging is ESD compliant then the expendable packaging **SHALL** also be ESD compliant.
- All hand held expendable packaging **SHALL** have a telescopic lid and hand holes, unless otherwise authorized by MBUSI Packaging Engineer/Specialist.

### TELESCOPIC OR SET-UP CONTAINERS

Identical labels **SHALL** be located on two adjacent sides of the inner box and visible when the telescopic lid is in place.

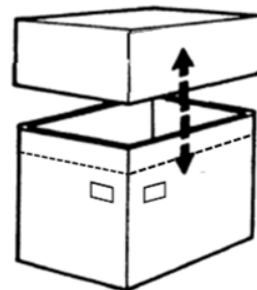

- All bulk bin expendable packaging **SHALL** have a telescopic lid and the box **SHALL** be secured to the complete wooden pallet that mimics the size of the bulk bin expendable box, unless otherwise authorized by MBUSI Packaging Engineer/Specialist.

### TELESCOPIC OR SET-UP CONTAINERS

Identical labels **SHALL** be located on two adjacent sides of the inner box and visible when the telescopic lid is in place.

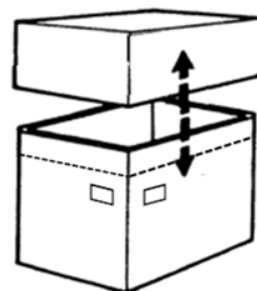

- All bulk bin expendable packaging and pallet loads of expendable hand held boxes must be clearly marked on all four (4) exterior sides of the box, in the visible center with the appropriate stack height. The appropriate stack height **SHALL** be printed on the expendable box close to the size of 8.5 inch x 11.0 inch, unless otherwise authorized by MBUSI Packaging Engineer/Specialist.



- **A separate Packaging Data Form SHALL be submitted for back-up expendable packaging for approval before the use of expendable packaging can be accepted.**
- All expendable packaging materials must be legally and economically disposable. If possible, avoid wood in expendable packaging due to disposable efforts.
- **Corrugated expendable packaging is not to be used in the Body Shop due to fire hazards.**
- The supplier is responsible for the design and procurement of expendable packaging (series one way or alternative packaging), as well as for ensuring part quality until the parts are received at MBUSI. Handheld tote expendables **SHALL** have a 2 flute wall thickness (BC) and 2 flute wall thickness (BC) telescopic (shoebox type) lid. Bulk bin expendables **SHALL** have a 3 flute wall thickness (CAA) and 2 flute wall thickness (BC) telescopic (shoebox type) lid in order to withstand stacking and transportation weights.

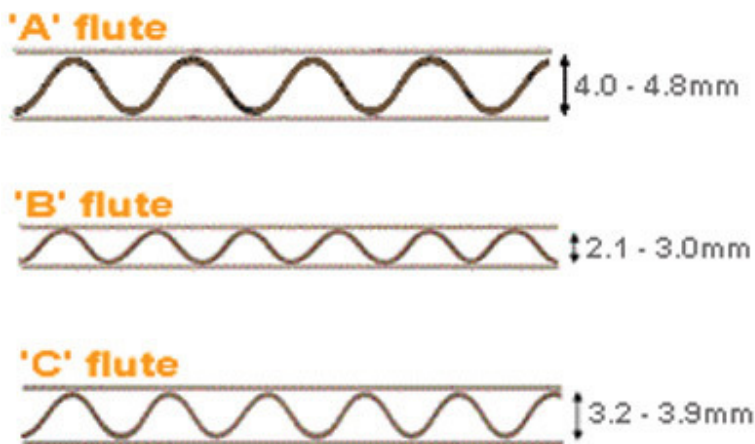

- The supplier **SHALL** use a standard NAFTA (45 inch x 48 inch) wooden pallet if the returnable pallets are not available at time of shipment. Palletized unit loads **SHALL** be stretched wrapped and banded (plastic or nylon) to the wooden pallet and lid. For safety reasons, steel banding is not acceptable. If a returnable lid is not available at the time of shipment then an expendable 2 flute wall thickness (BC) telescopic (shoebox type) lid **SHALL** be used. **The wood pallet and lid SHALL mimic the size of the unit load.**
- **Approval of the Reference Document SCGPA11 form does not provide official approval for commercial issue costs. It provides information as to what is being shipped and prevention of unapproved alternate packaging chargeback costs.**

- **Suppliers may not cancel shipments due to non-availability of returnable packaging or returnable components (inserts/dunnage). The supplier is required to have an adequate stock of alternative packaging to ensure production shipping can continue on schedule.**
- If you ship in corrugated **hand held** expendable packaging, please use the following packaging T5 codes in the ASN transmission (space is only shown for readability) and on the label. Make sure that relevant process descriptions and computer access is provided to the person at the shipping dock location. Reference SCGPA 16.

Expendable telescopic lid                    T5 80885  
 Wooden pallet                                    T5 80972

|   | ASN             | Label |
|---|-----------------|-------|
| Expendable packaging – footprint up to 12” x 7.5” (305mm x 191mm) | T5 <u>89224</u> | 89224 |
| Expendable packaging – footprint up to 15” x 12” (381mm x 305mm)  | T5 <u>89212</u> | 89212 |
| Expendable packaging – footprint up to 24” x 15” (610mm x 381mm)  | T5 <u>89206</u> | 89206 |
| Expendable packaging – footprint up to 24” x 22” (610mm x 559mm)  | T5 <u>89204</u> | 89204 |
| Expendable packaging – footprint up to 32” x 16” (813mm x 381mm)  | T5 <u>89232</u> | 89232 |
| Expendable packaging – footprint up to 48” x 15” (1219mm x 381mm) | T5 <u>89207</u> | 89207 |

- If you ship in corrugated **bulk bin** expendable packaging, please use the following packaging T5 codes in the ASN transmission (space is only shown for readability) and on the label. Make sure that relevant process descriptions and computer access is provided to the person at the shipping dock location. Reference SCGPA 16.

|  | ASN             | Label |
|--|-----------------|-------|
| Expendable packaging – footprint up to 42” x 29” (1057mm x 732mm)  | T5 <u>89645</u> | 89645 |
| Expendable packaging – footprint up to 45” x 24” (1143mm x 610mm)  |                 |       |
| Expendable packaging – footprint up to 45” x 48” (1143mm x 1219mm) | T5 <u>89601</u> | 89601 |
| Expendable packaging – footprint up to 48” x 57” (1219mm x 1454mm) | T5 <u>89657</u> | 89657 |
| Expendable packaging – footprint up to 48” x 64” (1219mm x 1638mm) | T5 <u>89664</u> | 89664 |
| Expendable packaging – footprint up to 48” x 70” (1219mm x 1778mm) | T5 <u>89670</u> | 89670 |

- Unspecified Expendable package                    T5 89999

## VI. ERGONOMICS AND SAFETY

- Hand held packaging must not exceed 15 kg (33 lbs.).
- The T5 20307 package may not exceed 12.2 kg (27 lbs.) due to its large size. (prior BR167 standard)
- Special hand held totes and trays must not exceed 12.2 kg (27 lbs.) due to its non standard size.
- All packaging in the Body Shop must be fire retardant in accordance with all applicable Occupational Safety and Health Administration Standards. Expendable packaging including expendable inserts/dunnage is not allowed in the Body Shop due to fire hazards. Receipt of such packaging could result in the Supplier immediately repacking material, expediting replacement shipments, or a line stoppage – all for which the Supplier will be responsible.
- All racks are to be free of sharp edges and burrs; limit the possibility of pinch points; and limit the ergonomic push/pull factors with opening or closing a rack.

- Inserts/dunnage **SHALL** allow easy access to the parts (e.g. finger notches in cell packs) and **SHALL** not have any sharp edges. All multiple layer inserts/dunnage **SHOULD** be stable enough to lift up, via ergonomic grip/hand holes, with parts inside and **SHALL** not exceed 11.4 kg (25 lbs.) with parts.
- All expendable packaging must have a telescopic lid and hand holes, unless otherwise authorized by MBUSI Packaging Engineer/Specialist. All expendable packaging **SHALL** also comply with all requirements of Section IV. EXPENDABLE PACKAGING.
- Hazardous material packages are reusable packages or non-returnable packages which are suitable – and have been tested and approved – for transportation of the relevant hazardous material in accordance with the applicable dangerous goods regulations.
- Safety-related equipment on the packaging must be used and maintained.
- Packages are not suitable for shipping to MBUSI if, for example. Failure to comply, will result in the packaging and parts being returned to the Supplier along with a chargeback. Severely damaged packaging will be scrapped and the responsibility of the Supplier to repurchase.
  - Corner pillars are deformed and or the frame is warped,
  - The front wall flaps are immovable or so distorted that they can no longer be closed, or if panel locks are not functional,
  - Flaps, rigid walls or side panels are missing,
  - The floor frame or the feet are so bent that the package can no longer stand evenly on all four feet or can no longer be stacked without danger,
  - Defects occur in the mechanical system which prevent the folding,
  - Feet are missing,
  - Gusset plates are torn open,
  - Round steel grids are fractured so that the wire ends protrude inward and outward,
  - They have sharp edges, visible cracks, punctures, or cracked bottom plates,
  - The identification plates are missing,
  - The general condition is so poor due to rust or soiling that cargo is soiled and/or
  - The functional mounting for load suspension equipment is not guaranteed.

## VII. PART COMBINATIONS

- Only one part number may be packed per package. If more than one part number is on one pallet then, the pallet must be properly labeled using the “MIXED LOAD” label. Pallets containing the same part number must be properly labeled using the “MASTER LABEL” label. (Reference the Supplier Communication Guide: SP Packaging - Labeling: Label Specification Vance, AL.)
- Parts manufactured to different engineering change levels must not be mixed in the same package or on the same pallet.
- Packaging for non-production parts such as trial and special order parts will be chosen in a joint effort between the Supplier and MBUSI.
- Suppliers **SHALL** trial packaging as soon as possible prior to new launches in order to implement the approved pack during the trial builds. ET or Engineering Trials and Null Series are the preferred deadlines for implementing the approved returnable packaging prototypes. Production approved returnable packaging is

required for ET Trials of conveyor delivered materials or those picked or placed with automated devices. All PT1 trials and beyond require the use of the production approved returnable packaging. Suppliers are expected to support these trials.

## VIII. LABELING

- All old HU (Part identification) labels and any remaining label residue **SHALL** be removed from the packaging prior to applying new HU labels on the Kennedy Placards or molded in placards.
- Prior to BR167. All packaging and racks require two part identification labels. (Exception is T5 22405 tote where only one part identification label is required.) These labels are to be applied to two adjacent sides of the package. Part identification labels must be completely visible after packages have been palletized for shipping. If plastic shrink wrap is used, labels must be scannable through the plastic.

BR167 and future projects. All totes, trays, bulk bins and JIT racks require two (2) HU labels. (Exception is T5 52405 tote where only one HU label is required.) These labels are to be applied to two adjacent sides of the package on the Kennedy placards or molded in placards. HU labels must be completely visible after packages have been palletized for shipping. If plastic shrink wrap is used, labels must be scannable through the plastic.

- Part identification labels must conform to the MBUSI Part Identification Label Standard, **3" x 6" label size with the new format**. Please periodically reference the Supplier Communication Guide: SP Packaging - Labeling: Label Specification Vance, AL for the needed HU label information. Illustrations of the locations of all HU labels are located in the Label Specifications, Exhibits 5A through 5D.
- All part identification labels **SHALL** be adhesive backed and used in conjunction with a 4.5" x 6.5" (Prior BR167) or 3.5" x 6.5" (BR167 forward) C001 'Placard' label holder from the Kennedy Group or with a molded in placard on bulk bins. For all Kennedy placard inquiries, contact them by phone number (440) 951-7660, via email [kennedygroup1@kennedygrp.com](mailto:kennedygroup1@kennedygrp.com), or via their website [www.kennedygrp.com](http://www.kennedygrp.com). All of our Approved Packaging Suppliers comply with the Placard standard.
- All information in the HU (part identification) label, except for the serial number, pack quantity, Q-level and ZGS level are transmitted to the Supplier via the EDI system. Reference Label Specifications section of the Supplier Communication Guide\_AM Supply for more information.
- Prior to BR167. **One or Two card holders will be provided on totes by the Approved Packaging Supplier for all new orders. This order card holder is only required for MBUSI internal delivery of modular packaging and SHALL not be utilized by the Supplier. Nothing SHALL be placed over this cardholder by the Supplier. Reference page 3 of this Specification for how many card holders are provided on each tote size.**
- BR167 and future projects. Card holders are no longer required.

## IX. PACKAGING IDENTIFICATION

- Prior to BR167: Reference Attachment "A" for how bulk bins and hand held packaging with insert/dunnage components are to be labeled. Reference Documents SCGPA03, SCGPA04, SCGPA05, and SCGPA15 for Label Artwork Forms



- **BR167 and future projects:** Reference Attachment “B” for how bulk bins and hand held packaging with insert/dunnage components are to be labeled. Reference Documents SCGPA19, SCGPA20, SCGPA21, SCGPA22, SCGPA23, and SCGPA24 for Label Artwork Forms
- All packaging must be identified for return purposes on all four sides with Supplier name, Supplier code and ship location. Please contact our Approved Packaging Suppliers to receive all MBUSI specifications.
- Using white lettering for standard totes and yellow lettering for ESD totes, each package **SHALL** have one hot stamp containing MBUSI information.

**Prior BR167 projects :** It **SHALL** read: Mercedes-Benz, Vance, Alabama, and package name.

Example: Standard tote

  
Mercedes-Benz  
(SPACE)  
Vance, Alabama  
2 1207

Example: ESD tote

  
Mercedes-Benz  
  
Vance, AL  
7-1207

Example: ESD tote lid

  
Mercedes-Benz  
  
Vance, AL  
5-0712

**BR167 projects forward:** It **SHALL** read: Mercedes-Benz, Vance, Alabama.

Example: Standard tote

  
Mercedes-Benz  
(SPACE)  
Vance, AL

Example: ESD tote

  
Mercedes-Benz  
  
Vance, AL

Example: ESD tote lid

  
Mercedes-Benz  
  
Vance, AL

- All returnable insert/dunnage components, including supplier-owned in the MBUSI loop, must be **permanently** labeled with the Supplier name, Supplier number, plant location and MBUSI “T5” packaging code to facilitate the return of the inserts to the appropriate supplier.
- All packaging that travel across U.S. borders must also contain one ownership label. The label must be legible and visible on the outside of the package. It is possible to provide the following information without the use of a label, as long as all the information is visible from the outside of the package.

| Ownership Label    |
|--------------------|
| Owner:             |
| Pack Code:         |
| and/or             |
| Pack Serial #:     |
| Tare Wt. (kg):     |
| Country of Origin: |

- **Prior to BR167:** All bulk bins/totes/tray packaging **SHOULD** be serialized by the Supplier in order to facilitate packaging counts at the Supplier’s docks. Counting packaging at MBUSI is difficult when production is running. Packaging on trailers between the Plants and the MLC are not available to be counted thus inaccuracies are known.

- BR167 and future projects: All bulk bins/totes/tray packaging include a RFID label with a serial number in order to facilitate packaging counts at the Supplier's docks. Counting packaging at MBUSI is difficult when production is running. Packaging on trailers between the Plants and the MLC are not available to be counted thus inaccuracies are known.

## X. RFID IDENTIFICATION – BR167 and future projects

- RFID stands for Radio-Frequency Identification.
- Hand held totes and trays will contain one (1) passive 4.1.25” x 0.75” RFID tag located on the hot stamp end. T552405 tote RFID tag will be located on one short side. Reference Attachment “B” for how hand held packaging with insert/dunnage components are to be labeled. Reference Documents SCGPA19 Label Artwork Form
- Bulk bins will contain one (1) passive 3.0” x 2.25” RFID tag, located on one (1) short end in recessed area. Reference Attachment “B” for how bulk bins and hand held packaging with insert/dunnage components are to be labeled. Reference Documents SCGPA24 Label Artwork Form
- Racks, EPP trays, pallets, and top caps currently do not have RFID tags.

## XI. STEEL RACK IDENTIFICATION

- Each steel rack will contain specific information, unique to each rack and Supplier. This information is to be stenciled using white lettering. The top horizontal bar would display the return to information. This would consist of the Supplier Name, followed by the Supplier code, and then the return to location, as shown in the following illustration at Point 1.

EXAMPLE: Return To: Behr-18544684-Dayton, Ohio

- It is the responsibility of each Supplier to maintain the serial number metal plate on each rack. This serial number **SHALL** be stamped or embossed onto the metal plate and screwed onto the rack on the top left inside vertical side of the corner support. (Illustration Point 2) An example of a 3”x1” label that is offered by MetalCraft, Inc. (1-800-437-5283) is shown below. Reference file number 06616 0005 01 to obtain formats, if interested in using.

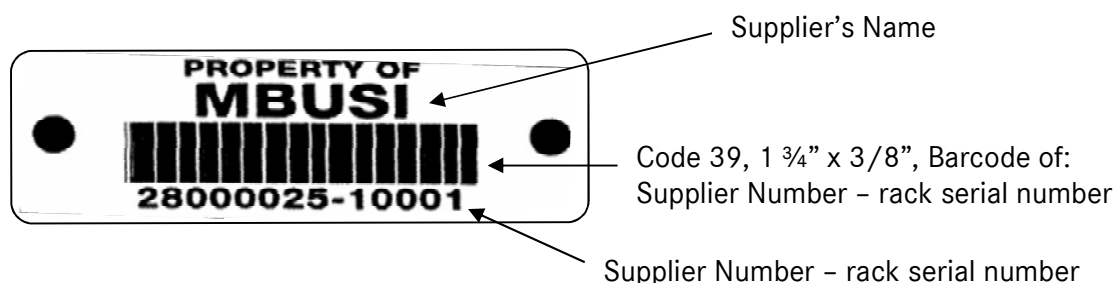

- As stated above, each JIT rack **SHALL** contain two identification placards on adjacent sides of the rack with a 3.5” x 6.5” C001 ‘Placard’ label holder (i.e. Kennedy placard), unless authorized by MBUSI Packaging Engineer/Specialist. This is shown at Point 5 on the following HU Rack illustration.



**HU Rack (JIT)**

**Sequence Rack (JIS)**

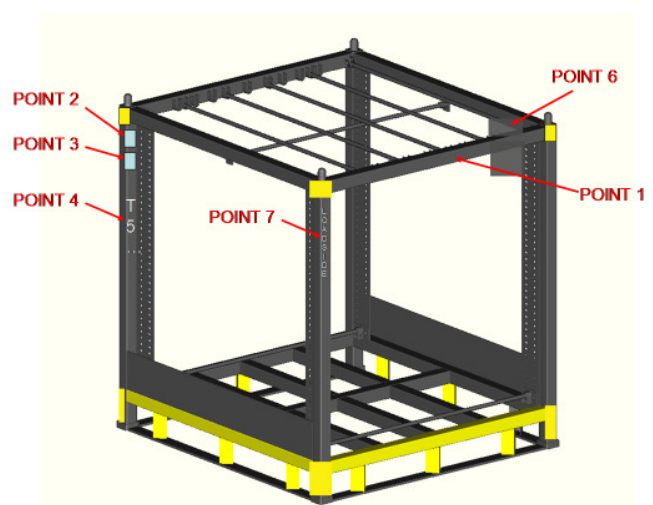
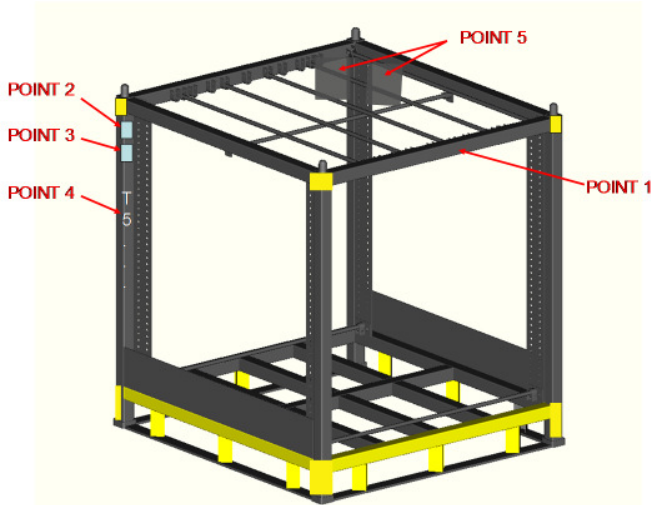

• **Number Identification Information – contact Packaging Engineer/Specialist with questions**

Point 1 = Location of Return To Information (all 4 sides of rack)

Point 2 = Location of Rack Serialization Label/Stencil (inner face of the left rear vertical column, from 1<sup>st</sup> pull position)

Point 3 = Location of Rack TPM Label (inner face of the left rear vertical column, from 1<sup>st</sup> pull position)

Point 4 = Location of Rack Identification Stencil (inner face of each vertical column)

Point 5 = Location of Adjacent JIT Identification Placards (2 per rack on adjacent sides) recessed inside frame

Point 6 = Location of JIS Broadcast Sheet pouch or placard

Point 7 = Location of Stenciling “LOADSIDE” associated with 1<sup>st</sup> cell of sequencing rack

- All racks **SHALL** also have a TPM (Total Preventative Maintenance) sticker indicating the date of the last TPM, date next TPM is due, frequency of TPM, and the individual performing the TPM. TPM audits are due to the MBUSI Packaging Engineer/Specialist on the 1st of each month. Reference Point 3 on above pictures.

- An example of the TPM sticker that could be used is as follows. Each Supplier **SHALL** use this sticker design on their metal racks. These Inspection stickers can be ordered from Worldwide Label & Packaging at (901) 454-9290.

This label can be used to show the status of TPM, PM, or general safety inspection. May be used on other applications as well.

**JUN 08**

Verified by \_\_\_\_\_

Verification Date    \_ / \_ / \_

Check Frequency     1 month    3 months  
                            6 months    12 months

**Visual indicator for the Month the next inspection is needed**  
(Label to go in a visible protected area for all TM's to see)

**Initials of Team Member that Performed Inspection**  
(Initials confirm "who" completed the current inspection)

**Date Inspection Performed**  
(Date shows confirmation of when TM completed inspection)

**Visual Indicator for how often Inspections should occur**  
(Frequency established by PM's or Standards)

|          |        |           |
|----------|--------|-----------|
| January  | Red    | July      |
| February | White  | August    |
| March    | Blue   | September |
| April    | Green  | October   |
| May      | Orange | November  |
| June     | Yellow | December  |



- Each rack **SHALL** have a Rack Identification (T5 number) stenciled onto the inner face of each vertical column, as shown in the following illustration at Point 4. This number will be provided by MBUSI Packaging Engineer/Specialist.

## XII. ASSEMBLY SHOP RACK SPECIFICATIONS

- All Assembly Shop Racks will have a base design and placard design as illustrated in Attachment “C”. Other fork pocket designs can only be used upon approval from a MBUSI Packaging Engineer/Specialist.
- All sequencing racks must have a pouch or placard attached to securely hold the Broadcast sheet.
- A six (6) inch tall 11 gauge kick plate **SHALL** be used on all bottom sides of rack not affected by removal of parts.
- **All Suppliers SHALL supply MBUSI with the most current Siemens NX or AutoCad Version drawings of the shipping and/or sequencing racks. This will provide MBUSI with the capability of determining, in advance, the impact to production and delivery methods (i.e. AGV, ATLS, installation point change, etc.) It is still the responsibility of the Supplier to verify if new parts will fit into the racks or if new racks will be needed. Daimler Share Point SHALL be used as the only means of information exchange when 15MB data is exceeded. Less than 15MB can be sent via email. Contact the MBUSI Packaging Engineer/Specialist for access directions.**
- As part of the Supplier’s process, they **SHOULD** obtain 1<sup>st</sup> Article audit sheets to be able to respond to any quality or safety issues that occur with the racks. The only time that MBUSI will require these audit sheets are when parts are robotically picked from the rack.

## XIII. BODY SHOP SPECIFICATIONS

- **Prior to BR205**
  - Each Body Shop Supplier will have a specific rack color to ensure proper return of the rack.
    - All Magna/Drive Automotive racks will be painted royal blue with yellow or orange stencil
      - Signal Blue- RAL# 5005
      - 166 Shipping Racks will have yellow stenciling (Traffic Yellow- RAL# 1023)
    - All Kamtek racks will be painted dark gray (Gauntlet Gray, SW7019).
    - All Gestamp racks will be painted black (TriCorn Black, SW6258).
  - Each rack **SHOULD** have a Rack Identification Label (T5 number) stenciled onto the inner face of each vertical column, as shown in the Section VII section illustration at Point 4. This number will be provided by MBUSI Packaging Engineer/Specialist.
  - Suppliers may use a “ring” designation for LH & RH part racks. A “ring” may be painted around the top corner posts. A white ring for LH parts and a green ring for RH parts.
  - The top inside portion of the other two opposite corner posts will be the Supplier code, city and state.

- All Body Shop Racks will have a truss base design as illustrated below. Other fork pocket designs can only be used upon approval from MBUSI Packaging Engineer/Specialist.
- **BR205 and future projects**
  - Contact the MBUSI Packaging Engineer/Specialist with packaging topics.

#### XIV. ROBOTIC RACK MAINTENANCE REQUIREMENTS

- All racks must maintain dimensional specifications as called out in the rack drawings which must be approved by the MBUSI Packaging Engineer/Specialist. Receipt of racks not in compliance could result in the Supplier immediately repacking material, expediting replacement shipments, or a line stoppage – all for which the Supplier will be responsible.

#### XV. RETURNABLE PACKAGING OWNERSHIP AND MANAGEMENT

- It is MBUSI's intention to have returnable packaging that does not present safety, quality or handling problems. Since all returnable packaging (including totes, trays, bulk bins, racks, inserts/dunnage, pallets and top caps) is purchased and maintained by the Supplier, it is the responsibility of the using parties to identify damaged or dirty packaging for removal from the system. It is also the Suppliers responsibility to replace packaging that falls out of the system (including totes, trays, bulk bins, racks, inserts/dunnage, pallets and top caps), at all times during its use, regardless of ownership.
- **All suppliers SHALL submit to MBUSI Packaging Engineer/ Specialist proof of order/quantity and receipt of all packaging including inserts/dunnage by T5 number. This is to verify packaging in the fleet and to assist with number of empty packaging to be returned per shipment.**
- MBUSI may establish and maintain a balance sheet returnable packaging tracking system confirming the amount of packages received with any shipment to MBUSI and the amount of packages shipped from MBUSI back to the supplier. The supplier **SHALL** participate in this system, including the ASN of returnable packaging if requested.
- It is the responsibility of the Supplier to return any returnable packaging (packages and/or interiors) that were not shipped properly to the correct Supplier on the next available shipment to MBUSI. The Supplier is to report the following information to the respective MBUSI Packaging Engineer/Specialist: date/time received the trailer; trailer number; Supplier's name(s), packaging type(s) and quantity received.
- Suppliers **SHALL** participate in returnable packaging inventories on a yearly basis or as requested by MBUSI.
- Prior to BR167: All bulk bins/totes/tray packaging **SHOULD** be serialized by the Supplier in order to facilitate packaging counts at the Supplier's docks. Counting packaging at MBUSI is difficult when production is running. Packaging on trailers between the Plants and the MLC are not available to be counted thus inaccuracies are known.
- BR167 and future projects: All bulk bins/totes/tray packaging include a RFID label with a serial number in order to facilitate packaging counts at the Supplier's docks. Counting packaging at MBUSI is difficult when production is running. Packaging on trailers between the Plants and the MLC are not available to be counted thus inaccuracies are known.

- The cost associated with the repair or replacement of any kind of returnable packaging will be the responsibility of the Supplier if not otherwise identified in the contracts. Initial purchases **SHOULD** anticipate normal loss and maintenance. The cost to store excess or repair material will be borne by the Supplier.
- MBUSI will tag any package or rack found damaged with a Repair Request Tag (See Document “REDTAG” for Assembly Shop and “YELLOWTAG” for Body Shop). All suppliers **SHALL** notify their MBUSI Packaging Engineer/Specialist of the date that a tagged package has been repaired. Any tagged package received back at MBUSI unrepaired will be charged for a non-conformance of packaging, in addition to the cost of repair of the package, **SHOULD** MBUSI find it necessary to perform such a repair (\$500.00 per incident charge back).
- If you have Monoflo bulk bins in your system, please reference <https://www.youtube.com/watch?v=8Zx6Yfjlp9w> or [https://www.youtube.com/watch?v=QUK1S\\_pwurg&feature=youtu.be](https://www.youtube.com/watch?v=QUK1S_pwurg&feature=youtu.be) for links that can be followed to view a video on handling, how to test the function, and make repairs. Order repair parts via the Monoflo contact listed in Section III of these specifications.
- If you have Buckhorn bulk bins in your system, please reference <http://www.buckhorninc.com/customer-care/care-handling.aspx> for a link that can be followed to view a video on handling, how to test the function, and make repairs. Order repair parts via the Buckhorn contact listed in Section III of these specifications.
- All investment including interest for packaging and maintenance must be amortized over the lifecycle of the program into the piece price. **At the end of the life cycle of the quoted carline, the packaging has been paid by Daimler. MBUSI has the option to take ownership of the total fleet of returnable packaging for the sum of \$1.00 USD.**

## XVI. TOTAL PREVENTIVE MAINTENANCE (TPM)

- All suppliers are to submit yearly and upon any changes made, a Total Preventative Maintenance (TPM) Procedure outlining what is being done to ensure all totes, bulk bins, trays, and racks are in good condition prior to shipment of parts to MBUSI. The TPM Procedure **SHOULD** describe how to identify that a package has been TPM'd and the schedule for TPMs. The TPM Procedures **SHOULD** be emailed to [MBUSIPackaging@daimler.com](mailto:MBUSIPackaging@daimler.com).
- The supplier is also to provide monthly reporting of TPM activity, which documents that all packaging is being TPM'd on a set schedule. This report is due on the first (1<sup>st</sup>) workday of each month for prior months activity by no later than the 10<sup>th</sup> calendar day of each month for the prior months activity. (Reference Document SCGPA17, MBUSI Monthly TPM Report Template (Prior BR67), SCGPA25, MBUSI Monthly TPM Report Template (BR167 forward.)
- All racks **SHALL** be clearly marked with the Month and Year that the next TPM is scheduled.
- A \$500.00 per month charge back will be submitted for Suppliers not providing monthly reporting of regularly scheduled TPMs.

## XVII. DEBIT AND PENALTIES SUMMARY

Suppliers will receive debits against receivables for non-conformities when parts are shipped in non-compliant packaging. For parts shipped in unapproved corrugated or unapproved alternate packaging- without written approval from the respective MBUSI Packaging Engineer/Specialist. (Reference Document SCGPA11 form when requesting by part number the use of alternate packaging. Blanket authorization will only be approved under very strict and specific circumstances.)

- Shipment of unapproved cardboard or unapproved packaging  
**(August 1, 2017 forward)** \$500.00 per bulk bin
- Shipment of unapproved cardboard or unapproved packaging  
**(August 1, 2017 forward)** \$50.00 per tote/tray
- Repack charges accrued due to unapproved use of packaging that is damaged or does not fit lineside \$35.00 per handling unit
- HU labels that do not meet MBUSI standards \$50.00 per handling unit
- Mixed Load/Master labels misuse or that does not meet MBUSI standards \$250.00 per handling unit
- Missing or broken cardholders on hand held totes \$25.00 per tote
- Non submittal of monthly report showing regularly scheduled TPMs \$500.00 per month
- Shipment to MBUSI of previously Repair Request tagged rack or packaging with product and without repair \$500.00 per incident
- Non submittal of packaging fleet purchase documentation – due 2 weeks after each SOP, volume increase, etc. (documentation to include packaging manufacturer, packaging/dunnage cost, quantity ordered and received. \$500.00 per month
- Non-submittal of final drawings for racks / dunnage / trays etc. \$500.00 per month per drawing
- Failure to submit Acknowledgement Sheet  
**(October 1, 2017 forward and for any revisions)** \$1000.00 per quarter

## XVIII. MBUSI-SUPPLIER COOPERATION

- **Parts SHALL be completely cooled and/or cured prior to packing in the approved packaging.**
- Approved packaging is for shipping purposes only and **SHALL** not be used for a Supplier's in-process material, storage of excess inventory, Tier 2 shipments, or bank builds unless specifically approved by the MBUSI Packaging Engineer/Specialist.
- MBUSI will complete a fleet calculation and provide Suppliers with a recommended minimum number of packages to order in order to support peak daily production.
- The fleet calculation takes into account the transportation routes, peak daily production volumes, option rates, and additional packaging to support color codes, and full pallet loads of totes and trays.

- Any returnable packaging that has been approved for shipments to Service Parts, SKD, BAIC or any other production build outside of the MBUSI facility must be purchased in addition to what is required to support production requirements.
- Packaging and the payment for bank builds **SHALL** be agreed upon between the Supplier, MBUSI Finance/Supplier Capacity Management & Tooling/Mercedes-Benz Purchasing Department in Germany and/or MBUSI Packaging Engineer/Specialist, prior to the build.
- Supplier-initiated ideas to improve the safety, quality, efficiency, or cost of the packaging are strongly encouraged, but must be tested (possibly via trial packaging shipments) and accepted by MBUSI Packaging Engineer/Specialist prior to implementation. **Suppliers SHALL submit pertinent information and a Packaging Data Form upon approval of the revisions.**
- MBUSI may assist with the packaging design and development, but will not be responsible or liable for non-performance of the final pack and any required redesigns of packs.
- The Supplier is responsible for relabeling packaging and ordering additional packaging when the “return to” location or supplier name changes. Costs for relabeling and ordering additional packaging **SHOULD** be considered in the supplier’s decision to move, as MBUSI will not be responsible for this cost.
- Suppliers **SHALL not** place anything over any hot stamps, return to labels, special dunnage labels or card holders. This will ensure that the proper packaging is returned to Suppliers.
- Suppliers may not deviate from shipping the approved returnable packaging without prior written authorization from MBUSI Packaging Engineer/Specialist. (Reference Document SCGPA11)
- Any changes in packaging or part number require resubmission of the Packaging Data Form and approval from MBUSI Packaging Engineer/Specialist. Costs resulting from non-compliance with accepted packaging will be charged to the Supplier.
- Suppliers **SHALL** notify MBUSI Packaging Engineer/Specialist at the earliest possible date when returnable packaging will become obsolete (due to part changes, etc.) to determine its proper reallocation.

## **XIX. STORAGE REQUIREMENTS**

- Suppliers are responsible for shipping production parts in packaging that are dust and debris free.
- Suppliers must ensure that the returnable packaging and inserts are free of debris and dust prior to loading with parts. If parts are shipped in dirty packaging, 100% of the resulting costs will be charged to the supplier.
- The supplier **SHOULD** have the capacity to store packaging, including the amount to cover peak volumes.
- **All empty unused totes/trays SHALL be stored upside down to prevent contamination. Totes/trays SHALL be arranged on standard MBUSI pallets. Totes/trays SHALL be stacked and covered with standard MBUSI top caps. Palletized totes/trays must be stretched wrapped to prevent contamination.**

- **All racks/bulk bins/totes/trays SHALL not to be stored outside and unprotected from the outside elements. If the Supplier can't store the empties protected, the Supplier has to inform the MBUSI Packaging Engineer/Specialist in written form about the reason, the period and why not other storage is possible (i.e. In a tent). The supplier has to show procedures to check the packaging, if necessary to clean it and to document the cleaning procedure (i.e. Cleaning sticker).**
- **Special inserts SHALL be stored in their respective packaging. The packaging SHALL be palletized and/or stacked with their respective inserts. Stacked or palletized packages containing inserts SHALL be stored in a covered area (protected from outside elements). Palletized packaging SHALL be covered with top caps.**
- **Standard packaging (bulk bins) SHALL be collapsed for storage to discourage contamination. The package at the top of the stack SHALL be covered to prevent contamination. Packaging is not to be stored outside, unprotected from the outside elements.**
- **Special packaging and Special racks with moving mechanisms (i.e. drop gates, swing arms), SHALL be stored in their closed and/or locked position. Packaging and racks are not to be stored outside, unprotected from the outside elements.**
- Packaging and/or racks **SHALL** be stacked securely only with like packaging/racks.

## XX. REFERENCE DOCUMENTS

- Bulk Bin Supplier ID Label Artwork Form.pdf (prior BR167) (Doc. Number: SCGPA03)
- Special Dunnage Tote Label Artwork Form.pdf (prior BR167) (Doc. Number: SCGPA04)
- Tote\_Supplier ID Label Artwork Form.pdf (Doc. Number: SCGPA05)
- Buckhorn specs pricing horizontal (prior BR167) (Doc. Number SCGPA07)
- Supplier Request to Use Alternate Pkg Form.pdf (Doc. Number: SCGPA11)
- Special Dunnage Bulk Bin Label Artwork Form.pdf (prior BR167) (Doc. Number: SCGPA15)
- Packaging code information (Spanish and English version) (Doc. Number SCGPA16)
- MBUSI Monthly TPM Report Template (prior BR167) (Doc. Number: SCGPA17)
- MBUSI BR167 forward pricing (Doc. Number SCGPA18)
- Tote RFID Label Artwork Form (BR167 forward) (Doc. Number SCGPA19)
- Bulk Bin Special Packaging Code Label Artwork Form (BR167 forward) (Doc. Number SCGPA20)
- Bulk Bin Standard Packaging Code Label Artwork Form (BR167 forward) (Doc. Number SCGPA21)
- Tote Special Packaging Code Label Artwork Form (BR167 forward) (Doc. Number SCGPA22)
- Tote Standard Packaging Code Label Artwork Form (BR167 forward) (Doc. Number SCGPA23)
- Red Assembly Shop Repair Request Tag (Doc. Number: REDTAG)
- Bulk Bin RFID Label Artwork Form (BR167 forward) (Doc. Number SCGPA24)
- Yellow Body Shop Defective Tag (Doc. Number: YELLOWTAG)
- MBUSI Monthly TPM Report Template (BR167 forward) (Doc. Number: SCGPA25)

Updated Bulk Bin Supplier ID Label  
6.5" x 3" label

**Bulk Box ID Tag – 25 inch height**



**Bulk Box ID Tag – 34 inch height**



**Bulk Box ID Tag – 40 inch height**

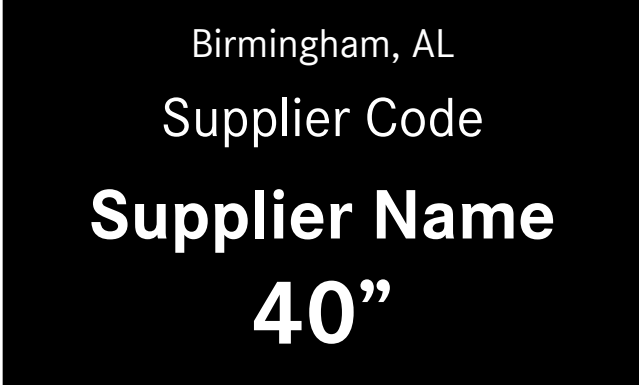

**Bulk Box ID Tag – 44 inch height**

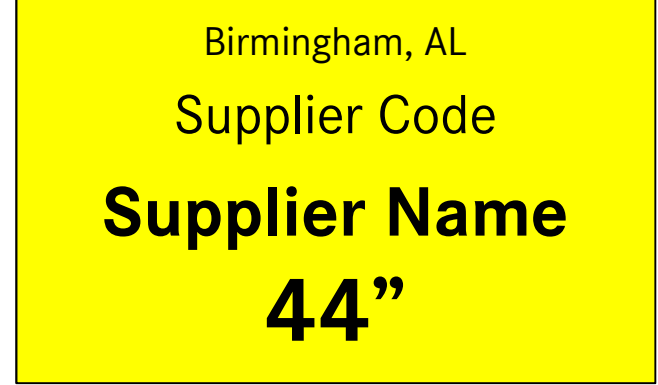

**Bulk Box ID Tag – 50 inch height**

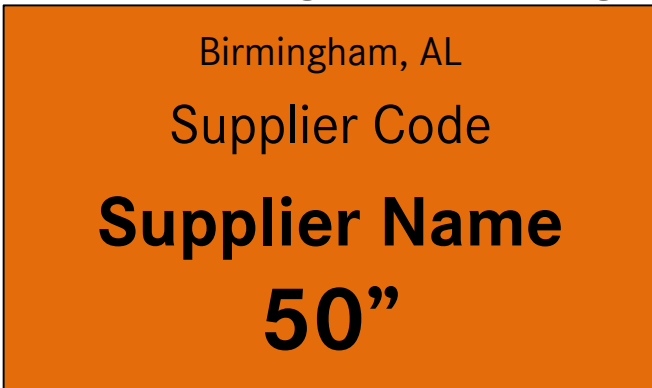

**Bulk Box ID Tag –  
T5 64228 – 28 inch height  
3.0" Long x 2.0" Tall tag**

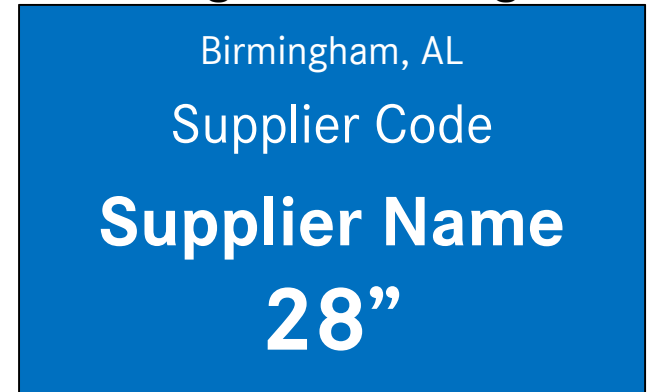



## Bulk Bins and Labels

- Bulk Bins without special inserts/dunnage will only get the colored, 4 line, Supplier ID Label
  - Placement will follow current placement on bulk bins – centered in the recess area
- Bulk Bins with special inserts/dunnage will receive the colored, 4 line, Supplier ID Label PLUS the Special 2 line Dunnage Label
  - Placement will be colored Supplier ID Label on left with Special Dunnage Label on the right inside the recess area

## Additional Bulk Bin Special Dunnage Label

To be used when a bulk bin contains inserts/dunnage

- White Label – **6.5" x 3"** label
- Black Lettering

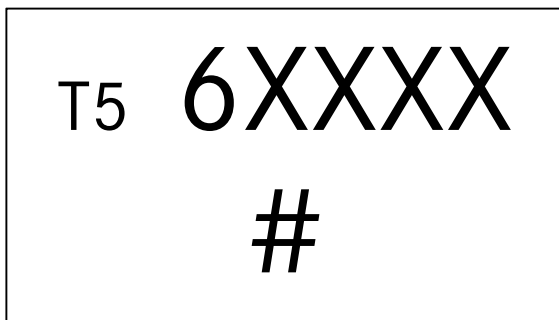

T5 2XXXX = hand held tote  
T5 6XXXX = bulk bin  
T5 7XXXX = ESD tote  
T5 5XXXX = pallet / lid

- We will use specific T5 6xxxx packaging codes for any bulk bins containing inserts/dunnage
- T5 simply means packaging - a packaging code with T5 **6XXXXX** means bulk bin with inserts/dunnage
- We would like to see the T5 font significantly smaller than the 6XXXXX with 6XXXXX bold
- We would like to see 2 spaces in between the T5 and the 6XXXXX
  - T5 6XXXX
- The “#” as the second line item pertains to the number of dunnage layers in the bulk bin.
- 1 dunnage layer = 1 on the second line, 3 dunnage layers = 3 on the second line, so on and so forth



## Attachment "A" - continued

T5 601 all heights without dunnage

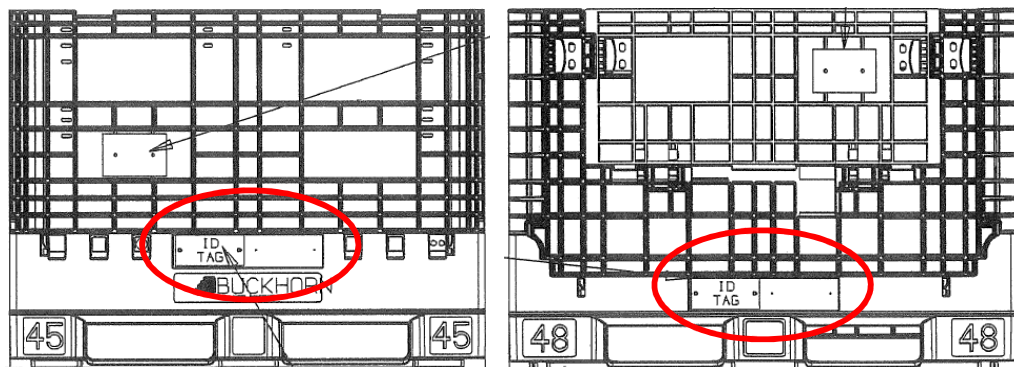

T5 60125\_T5 60134 with dunnage



T5 60140\_T5 60144 and T5 60150 with dunnage. Note: Dunnage Tag is 4.5" x 3".

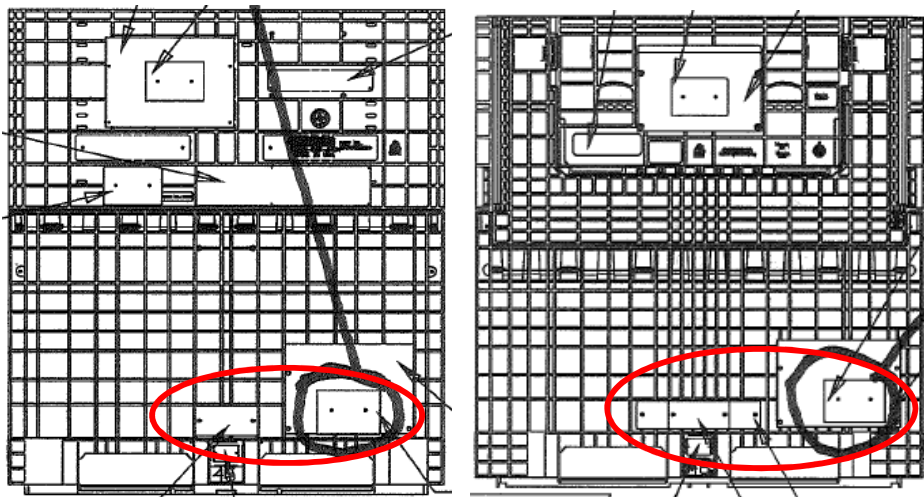

## Attachment "A" - continued

T5 657\_64\_70 all heights without dunnage

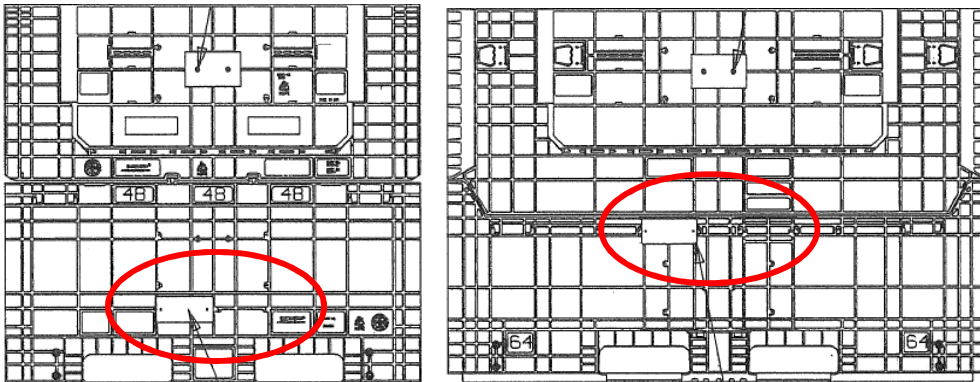

T5 657\_64\_70 all heights with dunnage

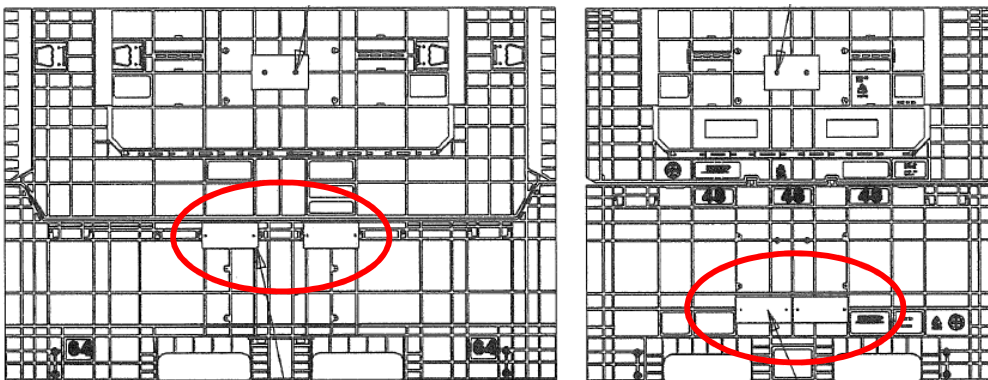

Attachment "A" - continued

## Additional Bulk Bin Special Dunnage Label

To be used when a bulk bin contains inserts/dunnage

- White Label – 3.0" x 2.0" label
- Black Lettering

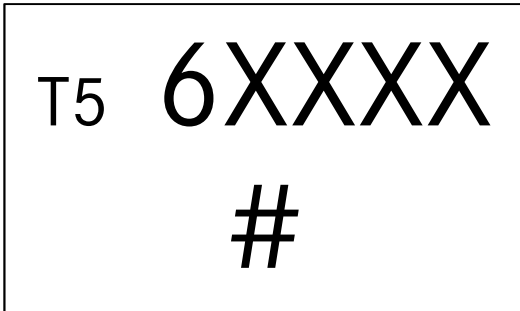

- We will use specific T5 6xxxx packaging codes for any bulk bins containing inserts/dunnage
- T5 simply means packaging - a packaging code with T5 6XXXX means bulk bin with inserts/dunnage
- We would like to see the T5 font significantly smaller than the 6XXXX with 6XXXX bold
- We would like to see 2 spaces in between the T5 and the 6XXXX
  - T5 6XXXX
- The “#” as the second line item pertains to the number of dunnage layers in the bulk bin.
- 1 dunnage layer = 1 on the second line, 3 dunnage layers = 3 on the second line, so on and so forth

### THIS PAGE FOR T5 64228 ONLY

2<sup>ND</sup> Label will be the same size as the existing label  
Placement to be in the rib above the existing label

|                           |
|---------------------------|
| T5 2XXXX = hand held tote |
| T5 6XXXX = bulk bin       |
| T5 7XXXX = ESD tote       |
| T5 5XXXX = pallet / lid   |

T5 64228 without dunnage

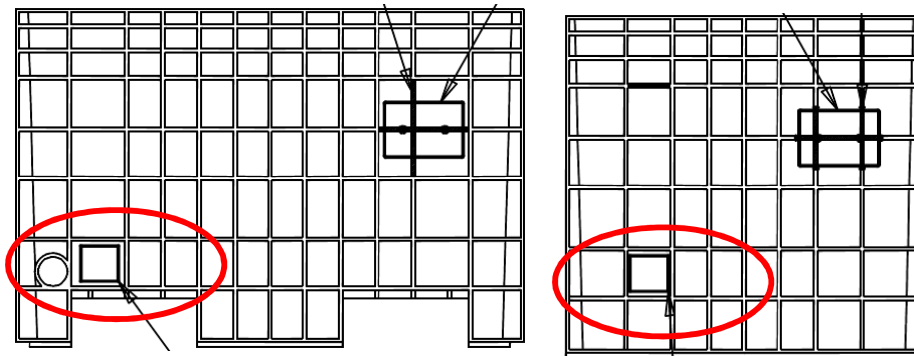

T5 64228 with dunnage

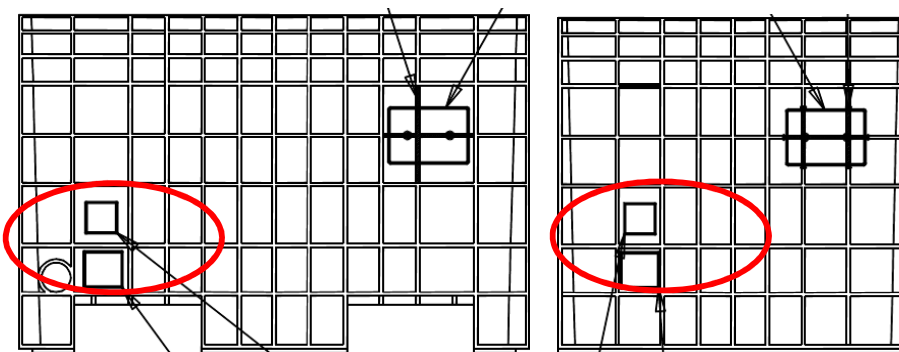

## Totes – Adding a second label

T5 2XXXX  
#

T5 2XXXX = hand held tote  
T5 6XXXX = bulk bin  
T5 7XXXX = ESD tote  
T5 5XXXX = pallet / lid

- We will use specific T5 2xxxx packaging codes for any hand held totes containing inserts/dunnage
- T5 simply means packaging - a packaging code with T5 **2XXXX** means hand held tote with inserts/dunnage
- We would like to see the T5 font significantly smaller than the 2XXXX with 2XXXX bold
- We would like to see 2 spaces in between the T5 and the 2XXXX
  - T5 2XXXX
- The “#” as the second line item pertains to the number of dunnage layers in the hand held.
- 1 dunnage layer = 1 on the second line, 3 dunnage layers = 3 on the second line, so on and so forth

## ESD Totes – Adding a second label

T5 7XXXX  
#

T5 2XXXX = hand held tote  
T5 6XXXX = bulk bin  
T5 7XXXX = ESD tote  
T5 5XXXX = pallet / lid

- We will use specific T57xxxx packaging codes for any ESD hand held totes containing inserts/dunnage
- T5 simply means packaging - a packaging code with T5**7XXXX** means ESD hand held tote with inserts/dunnage
- We would like to see the T5 font significantly smaller than the 7XXXX with 7XXXX bold
- We would like to see 2 spaces in between the T5 and the 7XXXX
  - T5 7XXXX
- The “#” as the second line item pertains to the number of dunnage layers in the hand held.
- 1 dunnage layer = 1 on the second line, 3 dunnage layers = 3 on the second line, so on and so forth

# Attachment "A" - continued

T5 22405 without dunnage

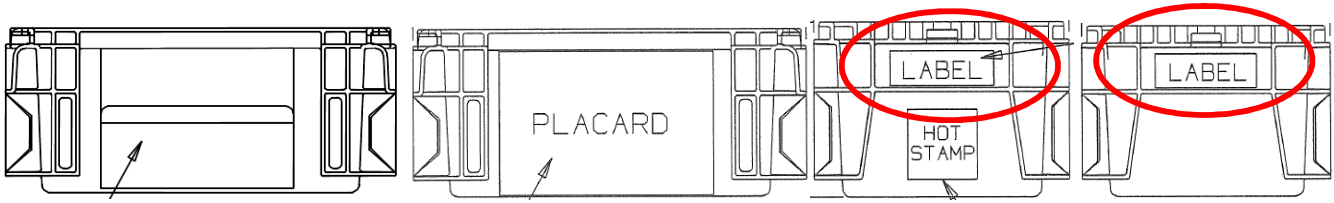

T5 2 and T5 7\_1207 without dunnage

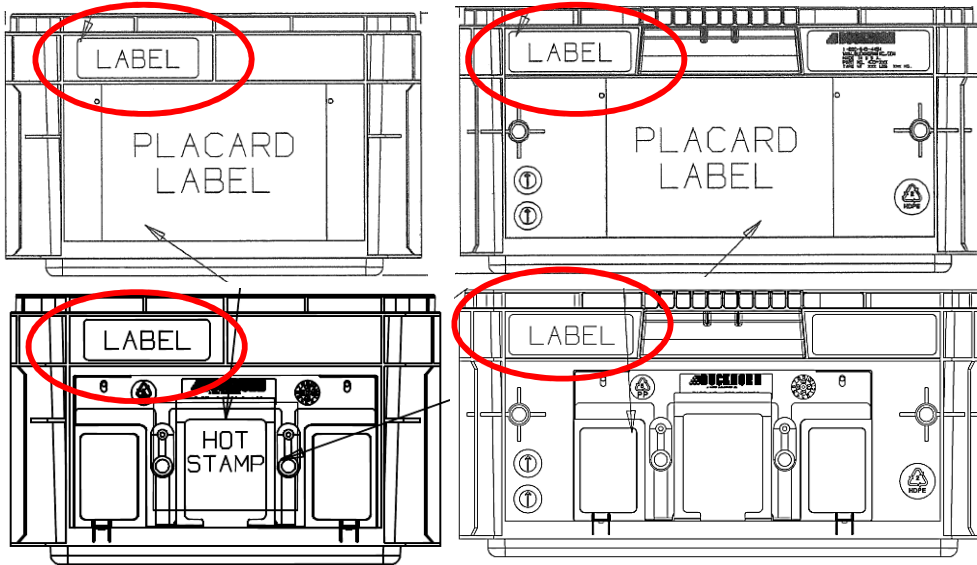

T5 2 and T5 7\_1207 with dunnage

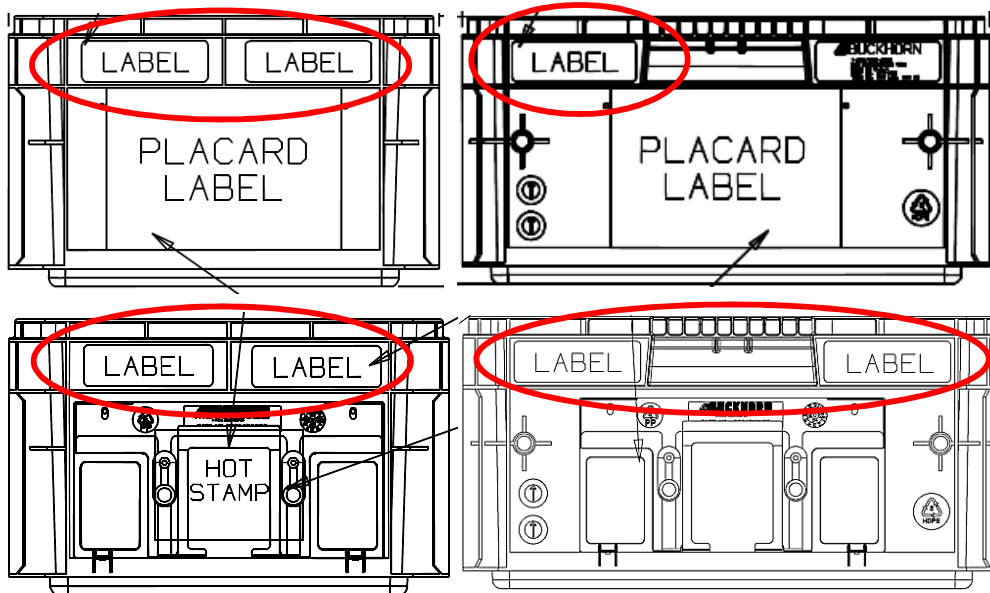



**Attachment "A" - continued**

T5 2 and T5 7\_0607 without dunnage



T5 2 and T5 7\_0607 with dunnage

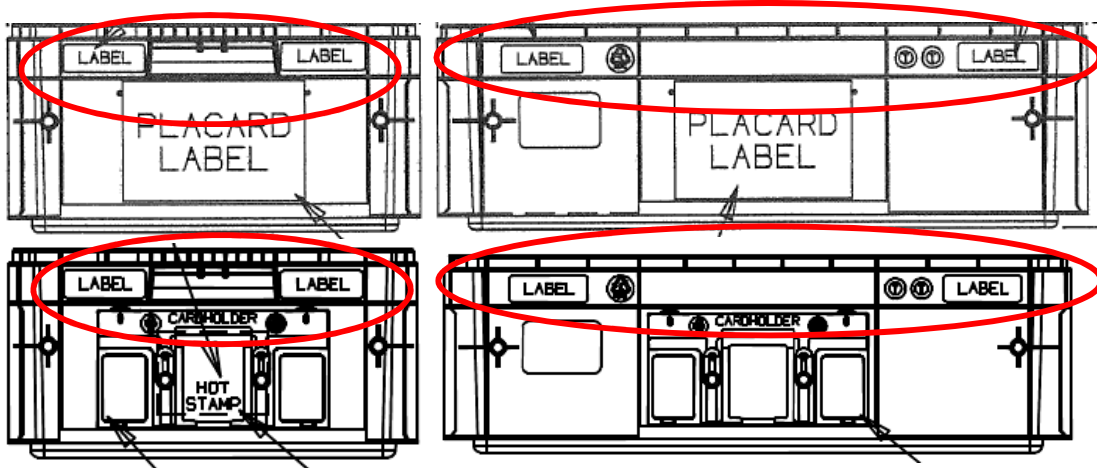

T5 2 and T5 7\_0609\_0614 without dunnage

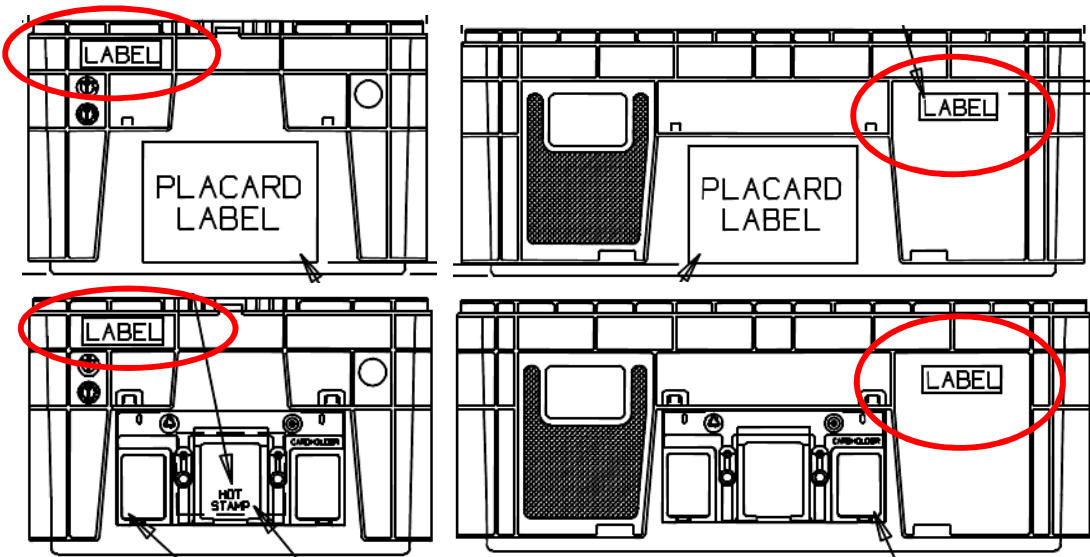

# Attachment "A" - continued

T5 2 and T5 7\_0609\_0614 with dunnage

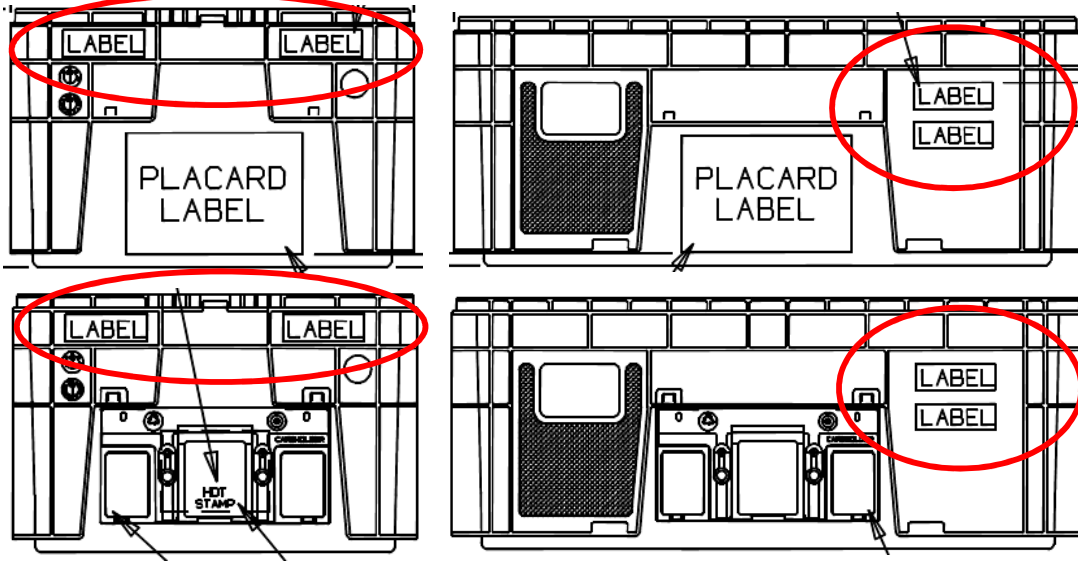

T5 2 and T5 7\_0407, T5 20411 and T5 20414 without dunnage



T5 2 and T5 7\_0407, T5 20411 and T5 20414 with dunnage

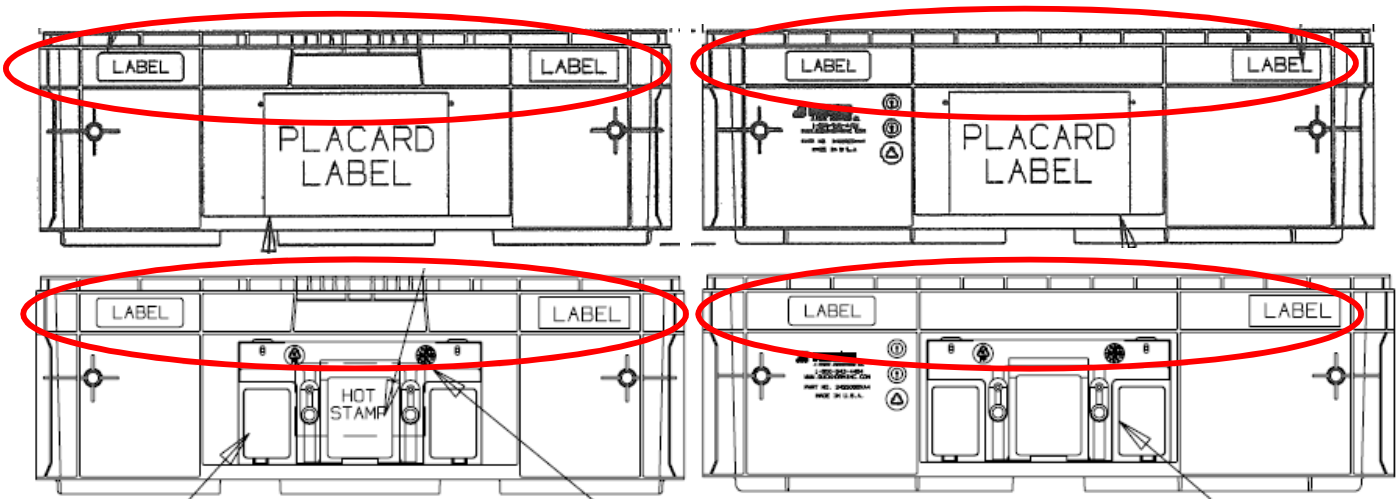

**Attachment "A" - continued**

T5 2\_3207\_0307 without dunnage

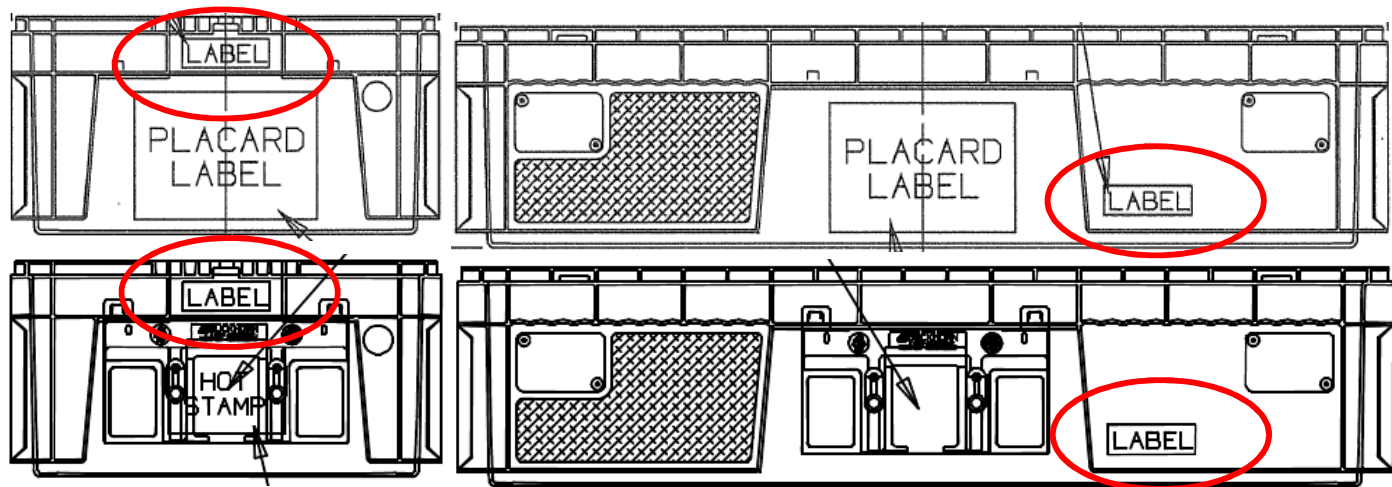

T5 2\_3207\_0307 with dunnage

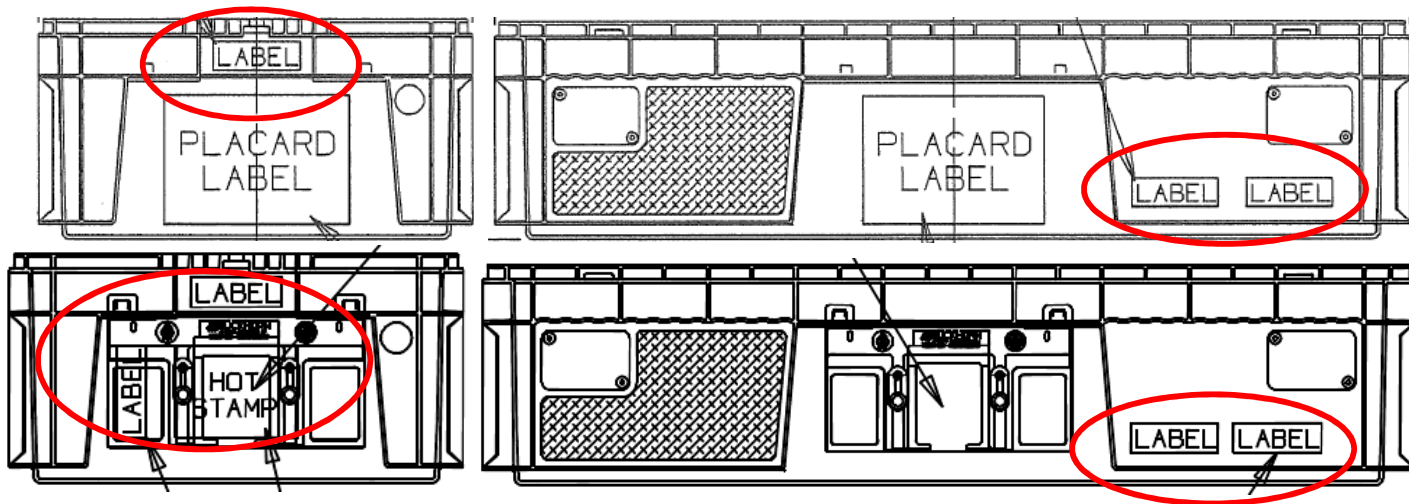

T5 50712\_T5 50706\_T5 50704 handheld tote lid with Supplier ID label

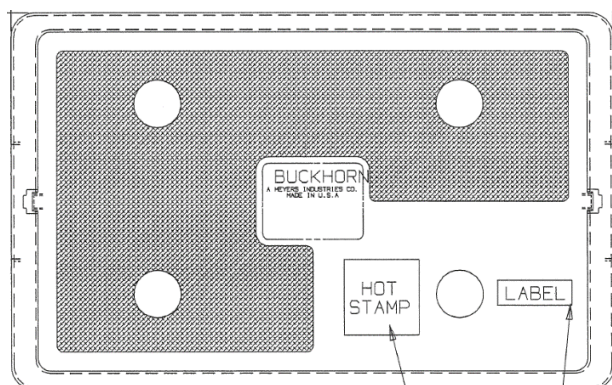



## Change of Existing Hot Stamps

### Hand Held Totes – X XXXX

- A24/05= 2 2405
- A12/07= 2 1207
- **A12/07E = 7 1207**
- A06/07 = 2 0607
- **A06/07E = 7 0607**
- A06/09 = 2 0609
- A06/14 = 2 0614
- **A06/14E = 7 0614**
- A04/07 = 2 0407
- **A04/07E = 7 0407**
- A04/11 = 2 0411
- A04/14 = 2 0414
- A3215/07 = 2 3207
- A03/07 = 2 0307

Updated Bulk Bin Supplier ID Tag  
6.0" x 2.0" tag

**Bulk Box ID Tag – 25 inch height**



**Bulk Box ID Tag – 34 inch height**

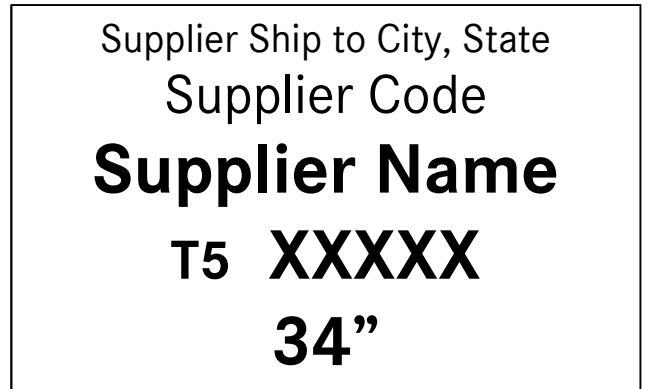

**Bulk Box with inserts/dunnage  
ID Tag – any height (pink)**



## Attachment “B” - continued

# Bulk Bins and Labels

- Bulk Bins without special inserts/dunnage will get the colored Supplier ID Label that corresponds with the height of the packaging and follow the label format as shown on Bulk Bin Supplier ID Label Artwork Form (Reference Document SCGPA21).
- Bulk Bins with special inserts/dunnage will receive the PINK, Supplier ID Label that follow the label format as shown on Bulk Bin Supplier ID Label Artwork Form (Reference Document SCGPA20).
- Placement of Supplier ID Label will follow current placement on bulk bins – centered in the recess area
  - T5 simply means packaging
  - We would like to see the T5 font significantly smaller than the 5XXXX and with 5XXXX in bold
  - We would like to see 2 spaces in between the T5 and the 5XXXX
    - T5 5XXXX
  - For special bulk bins, the “#” as the bottom line item pertains to the number of dunnage layers in the bulk bin.
    - 1 dunnage layer = 1 on the bottom line, 3 dunnage layers = 3 on the bottom line, so on and so forth

T5 5XXXX = standard packaging  
T5 57XXX = standard ESD packaging  
  
T5 2XXXX = special tote packaging  
T5 6XXXX = special bulk bin packaging  
T5 7XXXX = special ESD packaging

# Totes – Packaging Colors

- All standard totes will be the color as identified on page 6 and 7 of this specification and have white Packaging Code labels that follow the label format as shown on Tote Standard Packaging Code Label Artwork Form (Reference Document SCGPA23).
- All non-ESD **special** totes will be **Orange** in color and have **PINK** packaging code labels that follow the label format as shown on Tote Special Packaging Code Label Artwork Form (Reference Document SCGPA22).
- All ESD **special totes** will be conductive **Black** in color and have **PINK** packaging code labels that follow the label format as shown on Tote Special Packaging Code Label Artwork Form (Reference Document SCGPA22).

## Attachment “B” - continued

# Totes – Supplier ID Label

- All Supplier ID labels will be WHITE.
- Supplier ID labels will follow the label format as shown on Tote\_Supplier ID Label Artwork Form (Reference Document SCGPA05).
- Placement of Supplier ID Label will follow placement as called out for the Approved Packaging Supplier. Normally in the upper left hand corner of the tote, close to a rib.

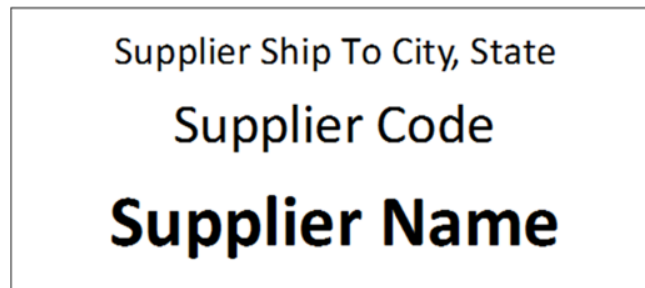

# Totes – Packaging Code Label

Standard totes

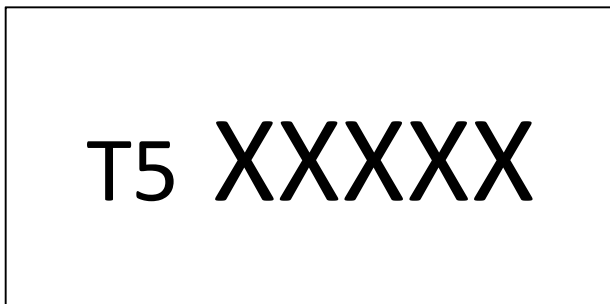

Special totes



- T5 simply means packaging.
- We would like to see the T5 font significantly smaller than the XXXXX and with XXXXX in bold
- We would like to see 2 spaces in between the T5 and the XXXXX
  - T5 5XXXX

## Attachment “B” - continued

- For special totes/trays, the “#” as the second line item pertains to the number of dunnage layers in the hand held package.
  - 1 dunnage layer = 1 on the second line, 3 dunnage layers = 3 on the second line, so on and so forth.

T5 5XXXX = standard packaging  
T5 57XXX = standard ESD packaging

T5 2XXXX = special tote packaging  
T5 6XXXX = special bulk bin packaging  
T5 7XXXX = special ESD packaging

LABEL #1 (2” x 6”) = Supplier ID label (colored for layout reference only)

LABEL #2 (2.25” x 3”) = RFID tag (colored for layout reference only)

LABEL #2 (4” x 6”) = Label placard or permanent label placard (colored for layout reference only)

T554525 Half Bulk Bin (Monoflo BC2444-25) – Standard has doors on short side only

Short side

Long side

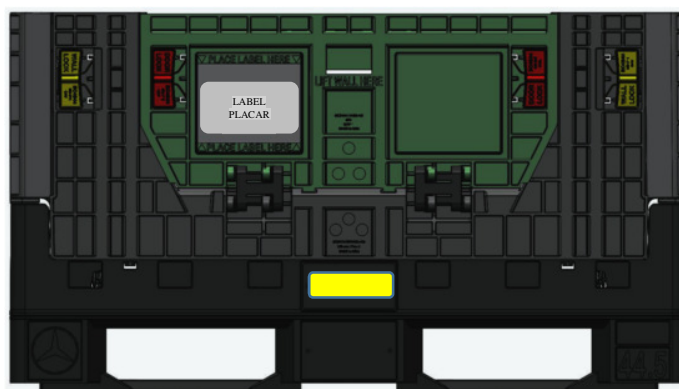
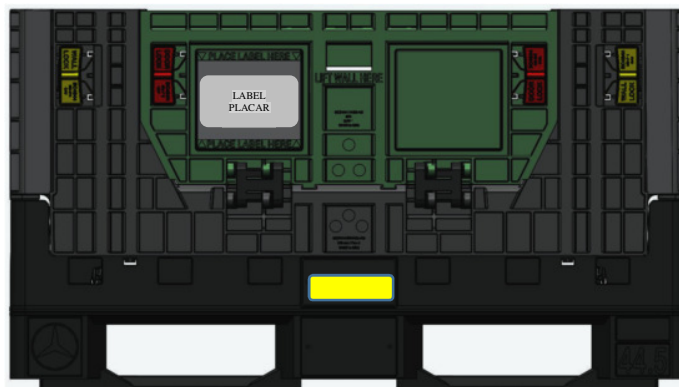
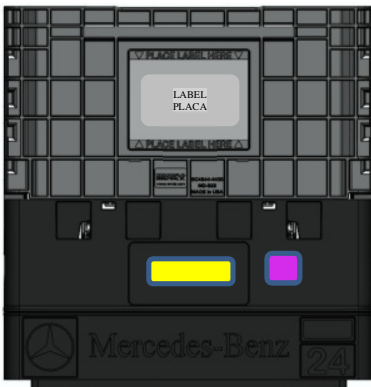

**Attachment "B" - continued**

**T5 50125 Bulk Bin (Monoflo BC4845-25 or G2 BC4845-25)**

Short side

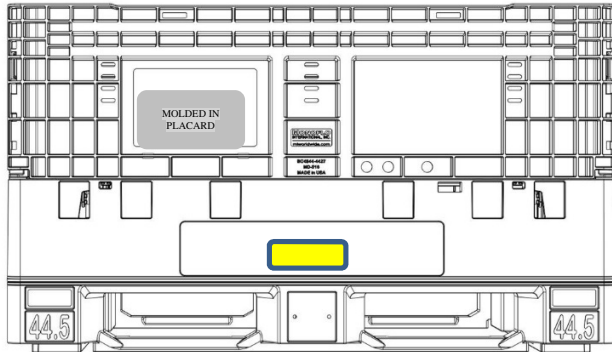
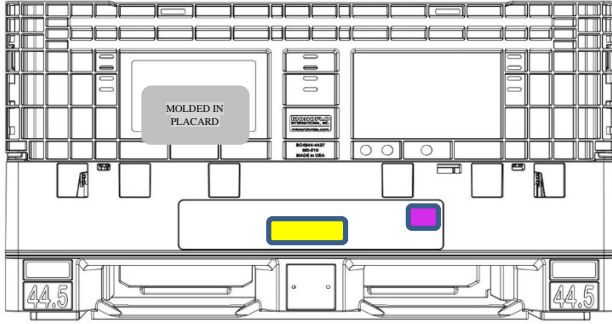

Long side

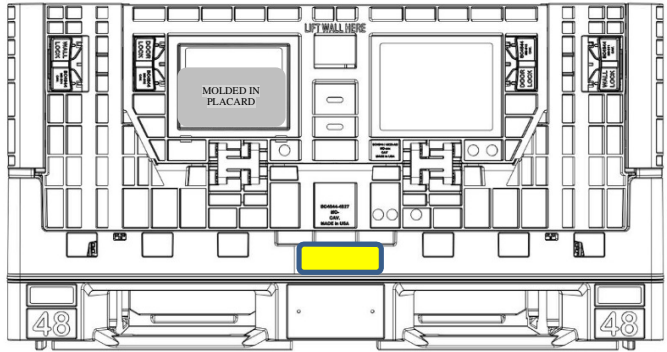
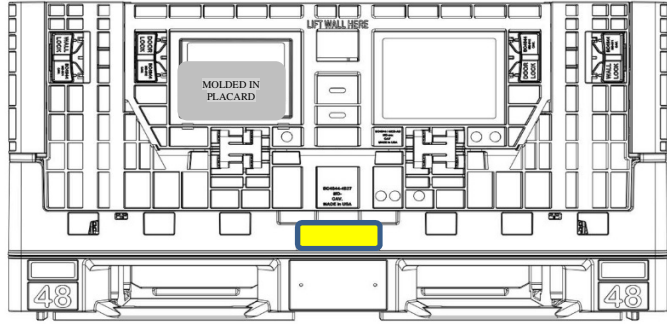

**T5 50134 Bulk Bin (Monoflo G2 BC4844-34)**

Short side

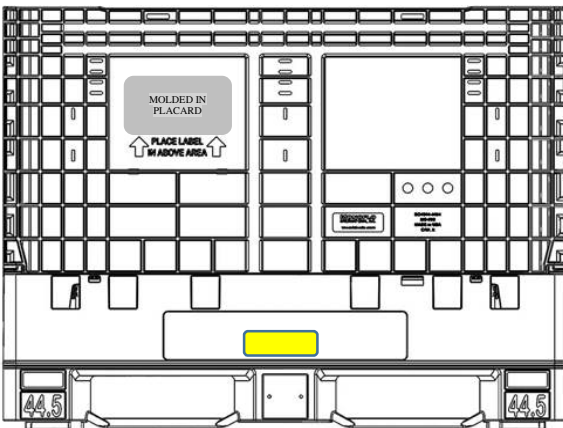
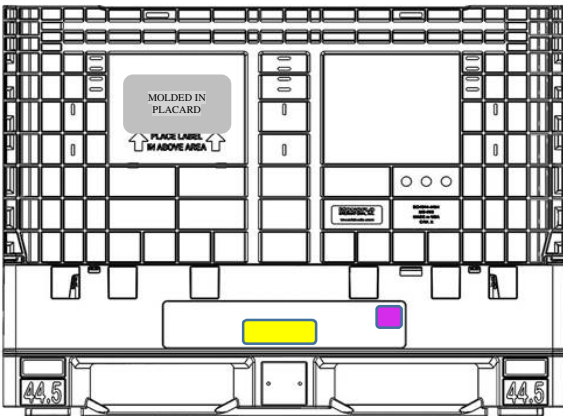

Long side

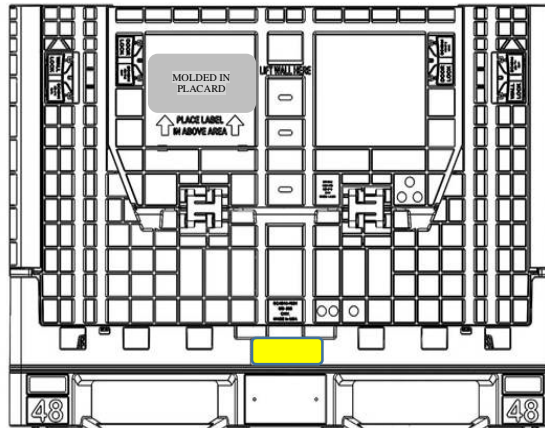
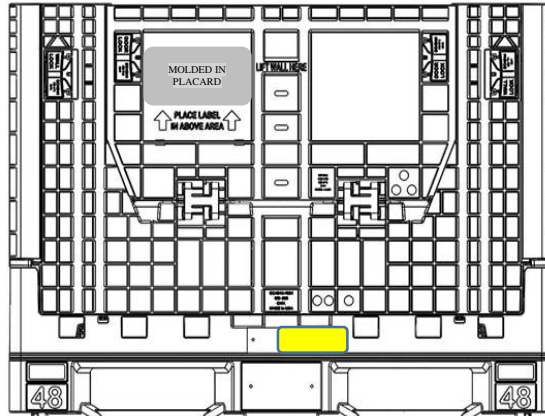

**Attachment "B" - continued**

All Buckhorn extended length bulk bins will have

- RFID label located on inside Center Foot on the 64" side under the foot cover.
- RFID ENABLED tag (1.0" x 2.875") will be secured within a rib on one 48" side showing that the bin has been RFID enabled.

RFID ENABLED

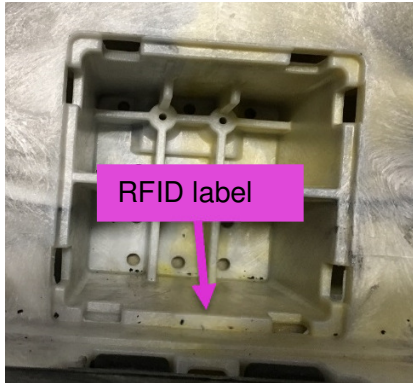

T5 56425 Bulk Bin (Buckhorn BS6448252210002)

Short side

Long side

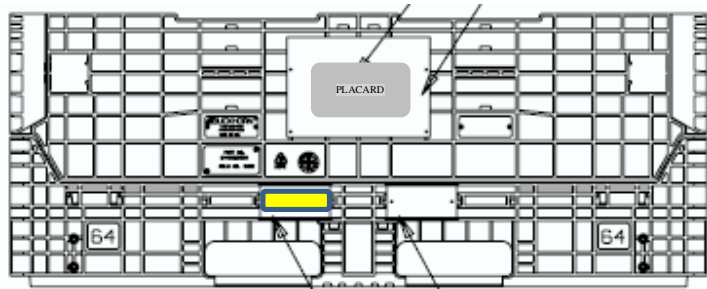
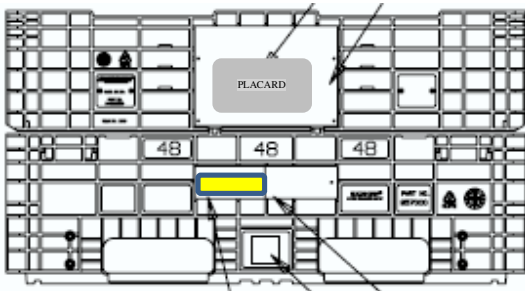
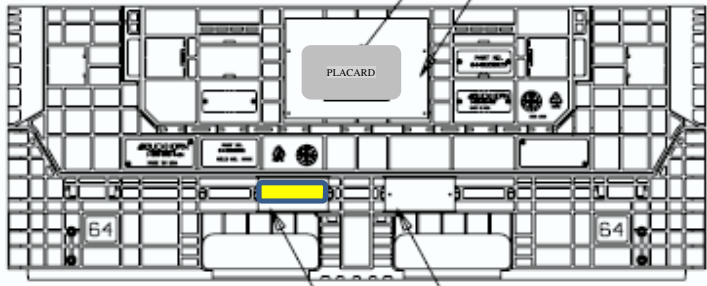
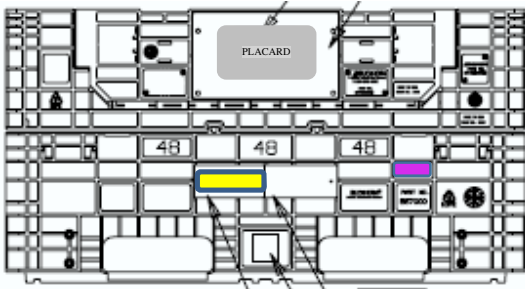



**Attachment "B" - continued**

**T5 56434 Bulk Bin (Buckhorn BS6448342210002)**

Short side

Long side



**T5 50102 Top Cap (Buckhorn TV484502FQ002)**



**T5 50106 Pallet (Buckhorn PM4845060010016)**

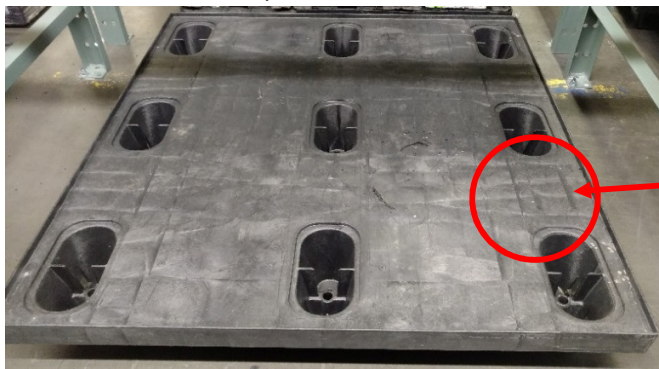



**LABEL #1 (1" x 3") = Supplier ID label** (colored for layout reference only)  
**LABEL #2 (1" x 3") = Container code** (colored for layout reference only)  
**LABEL #3 (.075" x 5") = Container code with RFID** (colored for layout reference only)  
**MBUSI Hot Stamp** = (colored for layout reference only)

(2.63 x 2.35 for T5 52405 and 57405 totes)  
 (2.62" x 2.8" for all other tote sizes)

**Kennedy Placard (3.5" x 6.5") = (colored for layout reference only)**

**T5 52405** (Schaefer AF120705RA) and  
**T5 57405** (Schaefer AF120705RAESD)

Short side

Long side

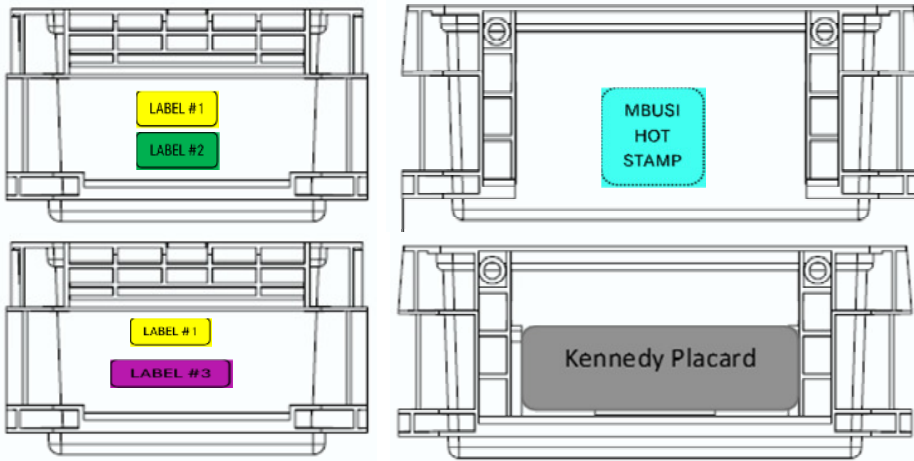

**Attachment "B" - continued**

**T5 51207** (Schaefer NF121507AS) and  
**T5 57207** (Schaefer NF121507ASESD)

Short side

Long side

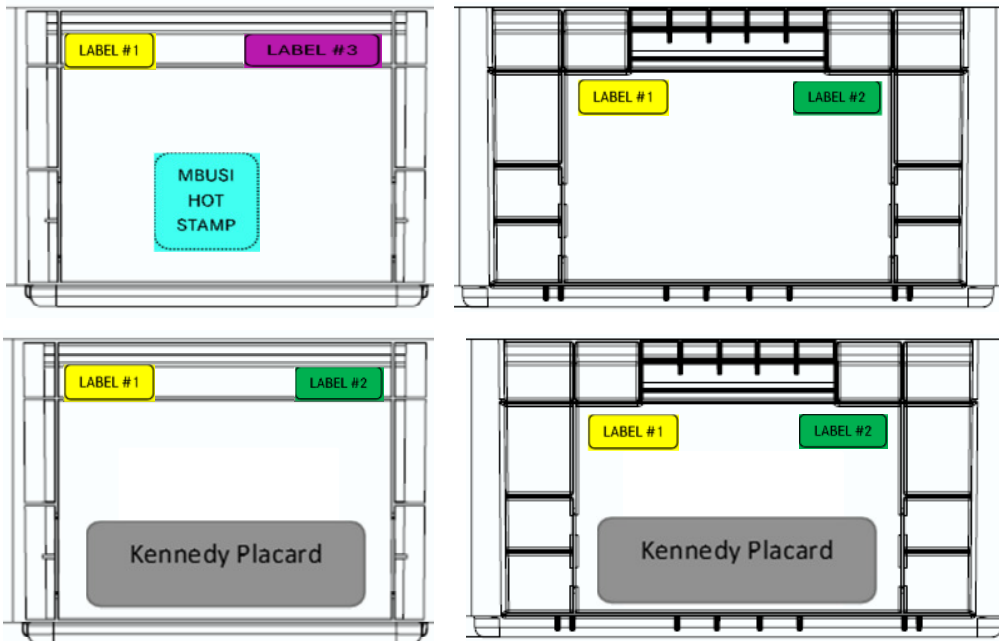

**T5 51211** (Schaefer NF121511AS) and  
**T5 57211** (Schaefer NF121511ASESD)

Short side

Long side

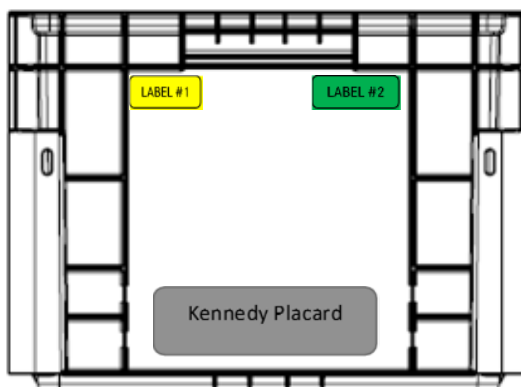
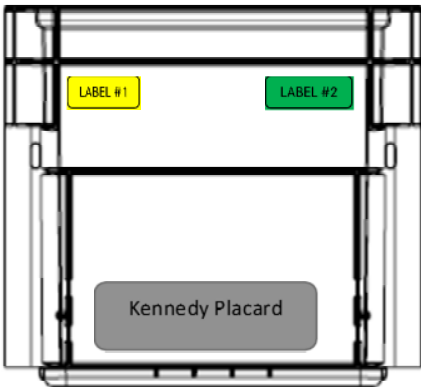
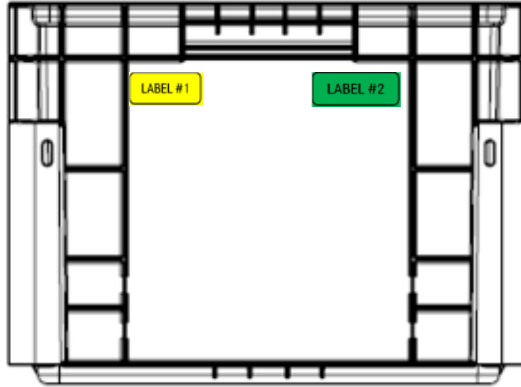
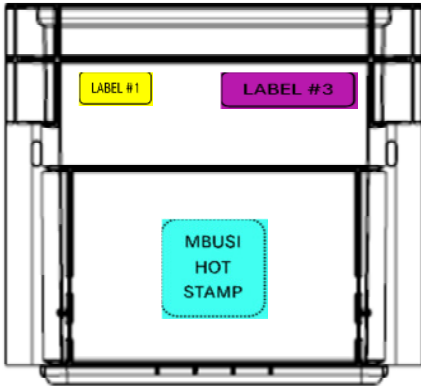

**Attachment "B" - continued**

**T5 50607** (Schaefer NF241507AP) and  
**T5 57607** (Schaefer NF241507APESD)

Short side

Long side

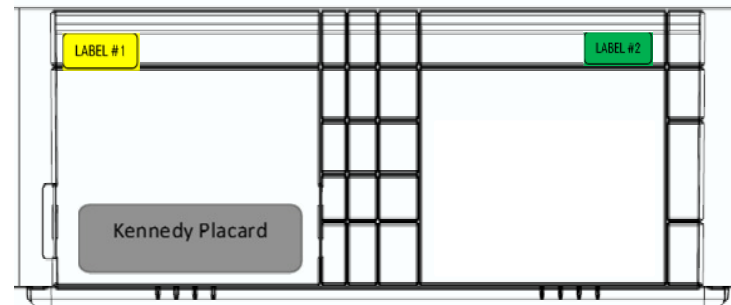
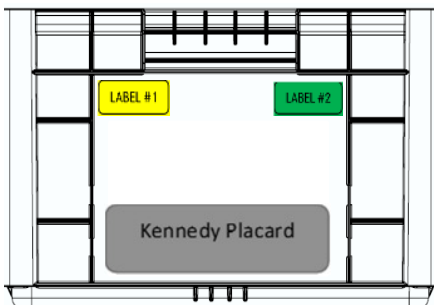
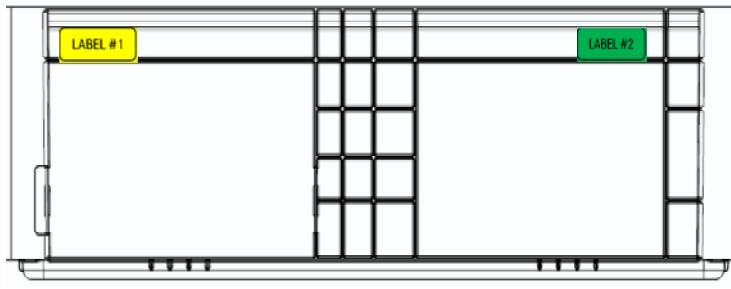
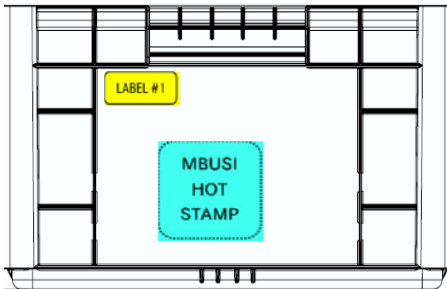

**T5 50611** (Schaefer NF241511AP) and  
**T5 57611** (Schaefer NF241511APESD) and

Short side

Long side

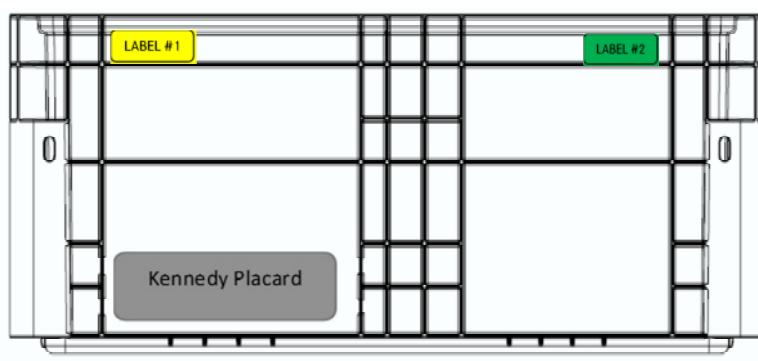
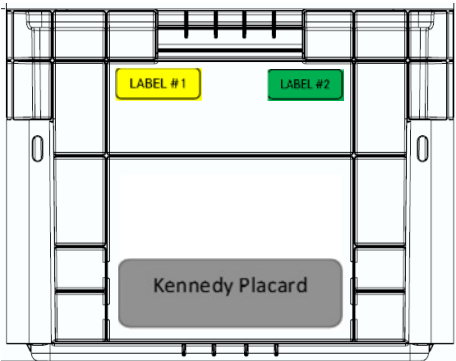
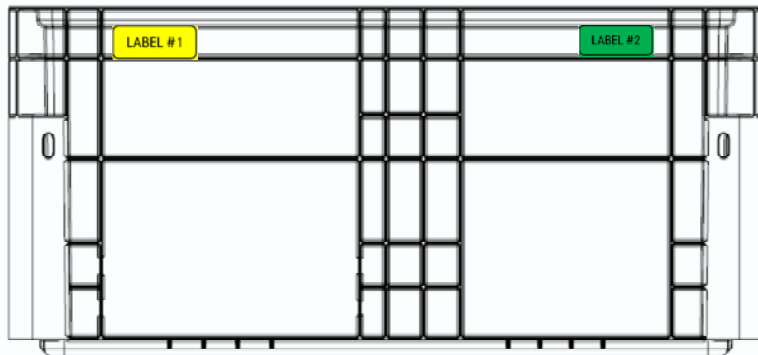
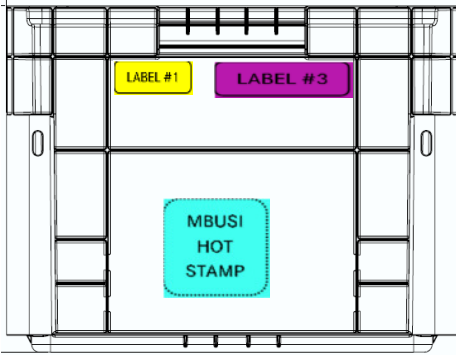

**T5 50712 Lid (Schaefer NF12150L.XXBK8 ESD)**

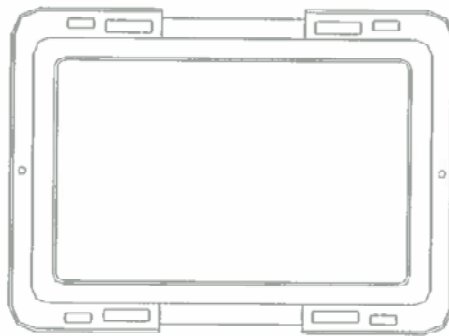
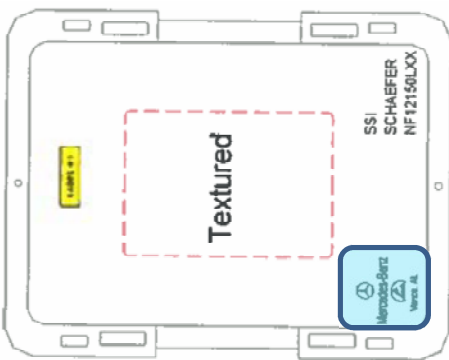

**T5 50706 Lid (Schaefer NF24150L.XXBK8 ESD)**

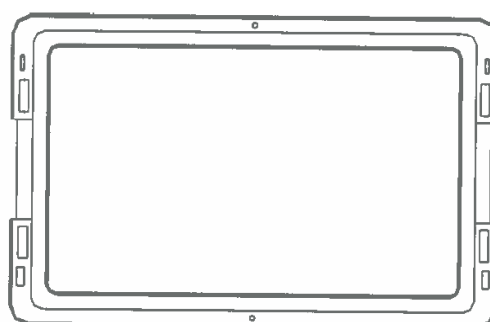
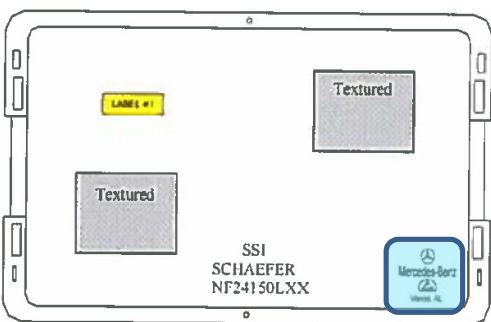

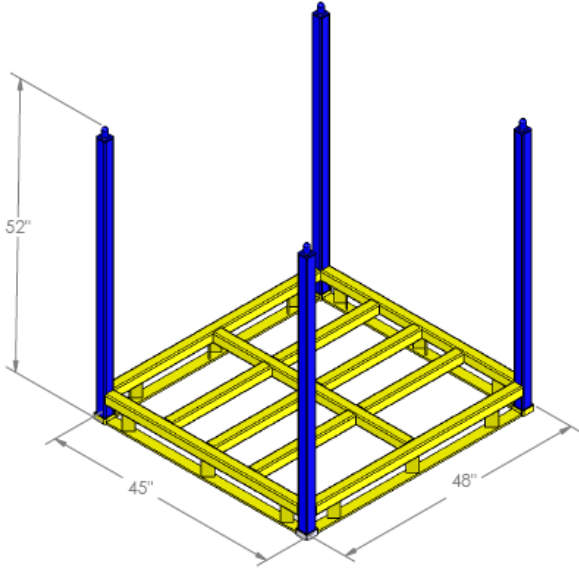

# Attachment "C" – Assembly Shop Standard Rack Base

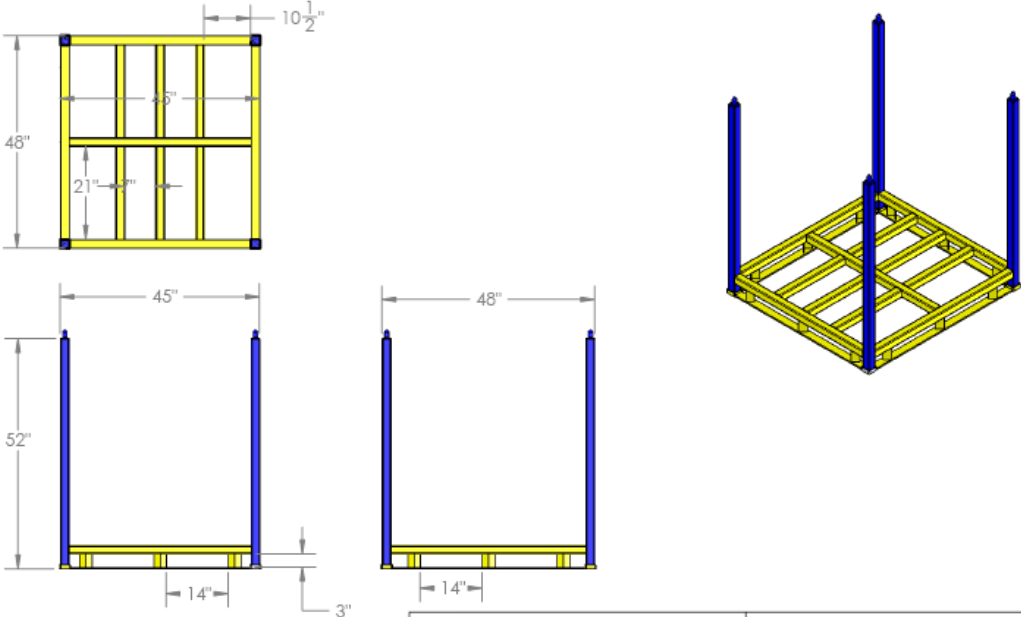

|  |                                     |   |                                    |
|--|-------------------------------------|---|------------------------------------|
| <br><b>Mercedes-Benz</b><br><b>U.S. International, Inc.</b> |                                     | Drawing Number:                           |                                    |
|  |                                     | Description:<br><b>STANDARD RACK BASE</b> |                                    |
| Drawn by:<br>JMH   | Approved:<br>C.L.                   | Date:<br>6/08/2007                        |                                    |
| P.O. Box 100<br>Tuscaloosa, AL 35403-0100  | 1 Mercedes Drive<br>Vance, AL 35490 | Scale:<br>1:16                            | Revisions:<br>0<br>Page:<br>1 OF 4 |

**NOTE: 100% WELDED UNLESS NOTED**





|  |                                     |   |                                    |
|--|-------------------------------------|---|------------------------------------|
| <br><b>Mercedes-Benz</b><br><b>U.S. International, Inc.</b> |                                     | Drawing Number:                           |                                    |
|  |                                     | Description:<br><b>STANDARD RACK BASE</b> |                                    |
| Drawn by:<br>JMH   | Approved:<br>C.L.                   | Date:<br>06/08/2007                       |                                    |
| P.O. Box 100<br>Tuscaloosa, AL 35403-0100  | 1 Mercedes Drive<br>Vance, AL 35490 | Scale:<br>1:24                            | Revisions:<br>0<br>Page:<br>2 OF 4 |

**NOTE: 100% WELDED UNLESS NOTED**

# Attachment "C" - continued

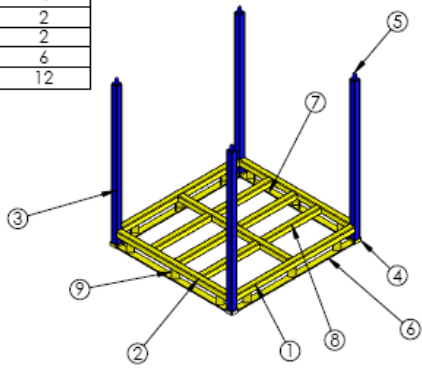
| ITEM NO. | PART NUMBER             | DESCRIPTION                      | QTY. |
|----------|-------------------------|----------------------------------|------|
| 1        | 7040 SIDE TS 2 X 2 X 44 | 11 GA. HRTS X 2" X 2" - 44"      | 2    |
| 2        | 7040 TS 2 X 2 X 41      | 11 GA. HRTS X 2" X 2" - 41"      | 3    |
| 3        | 7040 TS 2 X 2 X 52      | 11 GA. HRTS X 2" X 2" - 52"      | 4    |
| 4        | 7040 1" COLLAR          | 7 GA. HRTS X 2 1/2" X 2 1/2" - 1 | 4    |
| 5        | 7040 2sq STACKING CAP   | 2" STACKING CAP (LIV -1738-B-NH) | 4    |
| 6        | 7040 LONG 3-8 FLAT      | 3/8" HRFL X 2" - 43 1/2"         | 2    |
| 7        | 7040 SHORT 3-8 FLAT     | 3/8" HRFL X 2" - 40 1/2"         | 2    |
| 8        | 7040 TS 2 X 2 - 21      | 11 GA. HRTS X 2" X 2" - 21"      | 6    |
| 9        | 7040 FORKPOCKET DIVIDER | 1/4 HR ANGLE X 2" X 2" - 3"      | 12   |



|   |   |                   |                     |
|---|---|-------------------|---------------------|
| <br><b>Mercedes-Benz</b><br><b>U.S. International, Inc.</b><br><small>P.O. Box 100 Tuscaloosa, AL 35403-0100</small> | Drawing Number:                           |                   |                     |
|   | Description:<br><b>STANDARD RACK BASE</b> |                   |                     |
|   | Drawn by:<br>J.M.H.                       | Approved:<br>C.L. | Date:<br>06/08/2007 |
|   | Scale:                                    | Revisions:<br>0   | Page:<br>3 OF 4     |

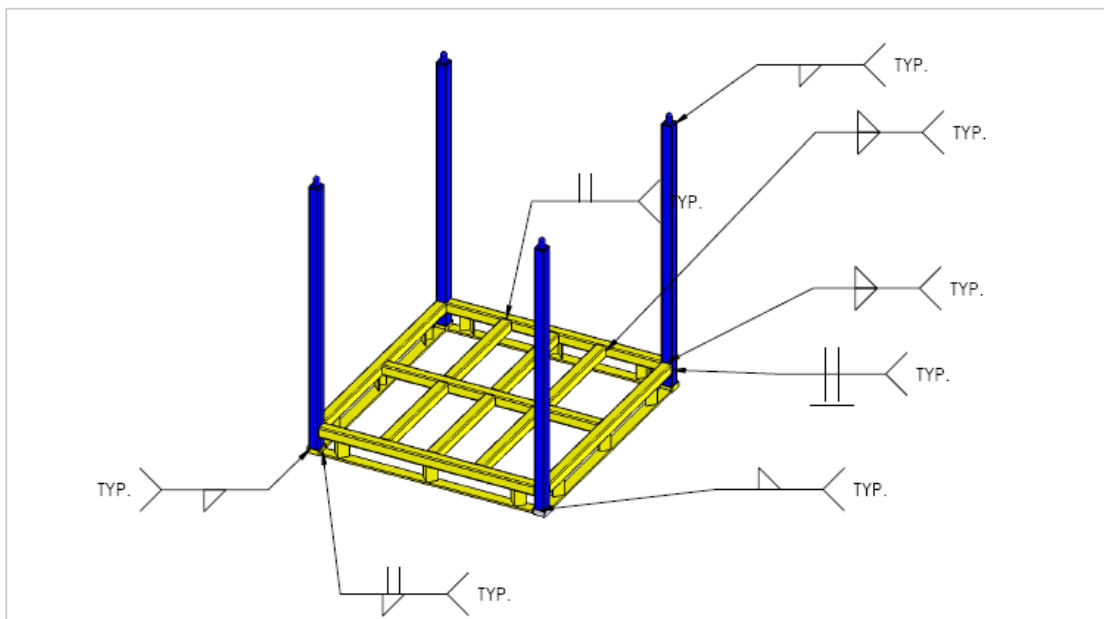

|   |   |                   |                     |
|---|---|-------------------|---------------------|
| <br><b>Mercedes-Benz</b><br><b>U.S. International, Inc.</b><br><small>P.O. Box 100 Tuscaloosa, AL 35403-0100</small> | Drawing Number:                           |                   |                     |
|   | Description:<br><b>STANDARD RACK BASE</b> |                   |                     |
|   | Drawn by:<br>J.M.H.                       | Approved:<br>C.L. | Date:<br>06/08/2007 |
|   | Scale:<br>1:18                            | Revisions:<br>0   | Page:<br>4 OF 4     |

Creation Date: 24 July 2012  
 Revision Date: 19 February 2018  
 Document Number: SCGPA10  
 Created by: Logistics Packaging Department

## Attachment "C" - continued

Rack placard dimensions

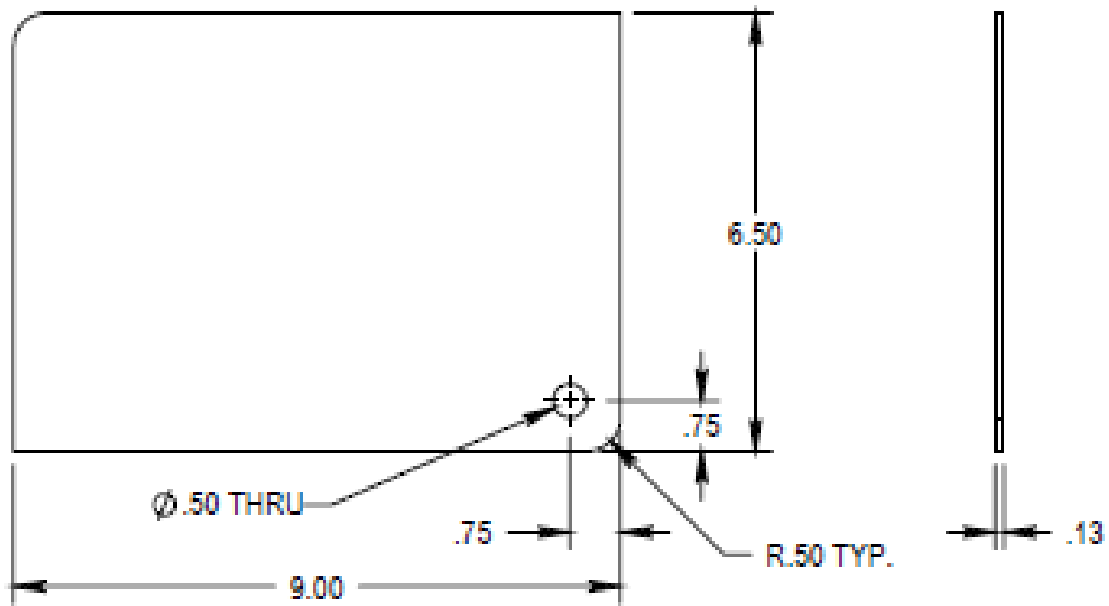

# Acknowledgement Sheet – Packaging Specifications

Submit completed Acknowledgement Sheet to [MBUSIPackaging@daimler.com](mailto:MBUSIPackaging@daimler.com)

Supplier Name: \_\_\_\_\_

Supplier Number: \_\_\_\_\_

I, \_\_\_\_\_ (Contact Name) from above listed Supplier, agree that I have fully read and understand the above Packaging Specifications and will comply with said document. If I have a successor, then I will train and hand over all history and documents pertaining to these Packaging Specifications. The successor will be responsible to sign a new Acknowledgment Sheet and submit to [MBUSIPackaging@daimler.com](mailto:MBUSIPackaging@daimler.com).

Packaging Specification Revision Level: \_\_\_\_\_

|              |           |       |
|--------------|-----------|-------|
| _____        | _____     | _____ |
| Printed Name | Signature | Date  |

|                         |           |       |
|-------------------------|-----------|-------|
| _____                   | _____     | _____ |
| Management Printed Name | Signature | Date  |